

**FEATURES**

- **Small & slim size**  
Twin type: 17.4(L)×14.0(W)×13.5(H)mm  
.685(L)×.551(W)×.531(H)inch  
Slim 1c type: 17.4(L)×7.2(W)×13.5(H)mm  
.685(L)×.283(W)×.531(H)inch
- **Twin (1 Form C × 2)**  
Forward/reverse motor control is possible with a single relay.
- **Simple footprint enables ease of PC board layout**

**TYPICAL APPLICATIONS**

- Power windows
- Auto door lock
- Power sunroof
- Electrically powered mirrors
- Powered seats
- Lift gates
- Slide door closers, etc.  
(for DC motor forward/reverse control circuits)

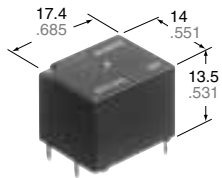

Twin type (8 terminals)

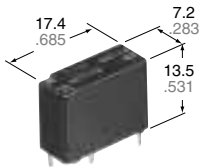

Slim 1c type

mm inch

※10 terminals layout

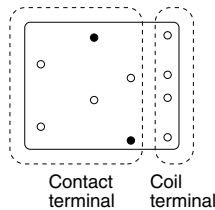

○ = 8 terminals

**SPECIFICATIONS**

**Contact**

|  |                            |   |  |
|--|----------------------------|---|--|
| Arrangement  | 1 Form C×2,<br>1 Form C    |   |  |
| Contact material   | Silver alloy               |   |  |
| Initial contact resistance<br>(By voltage drop 6 V DC 1 A) | Max. 100mΩ                 |   |  |
| Initial contact voltage drop                               | Max. 0.2 V (at 10 A)       |   |  |
| Rating   | Nominal switching capacity | N.O.: 20 A 14 V DC<br>N.C.: 10 A 14 V DC  |  |
|  | Max. carrying current      | 35 A for 2 minutes,<br>25 A for 1 hour<br>(14 V, at 20°C 68°F)<br>30 A for 2 minutes,<br>20 A for 1 hour<br>(14 V, at 85°C 185°F) |  |
|  | Min. switching capacity#1  | 1 A 12 V DC   |  |
| Expected life<br>(min. operation)                          | Mechanical (at 120 cpm)    |   |  |
|  | Electrical                 | Resistive load  | Min. 10 <sup>5</sup> *1  |
|  |                            | Motor load  | Min. 2×10 <sup>5</sup> *2 (free)<br>Min. 10 <sup>5</sup> *3 (lock) |

**Coil**

|                         |        |
|-------------------------|--------|
| Nominal operating power | 800 mW |
|-------------------------|--------|

#1 This value can change due to the switching frequency, environmental conditions, and desired reliability level, therefore it is recommended to check this with the actual load.

**Remarks**

- \*1 At nominal switching capacity, operating frequency: 1s ON, 9s OFF
- \*2 N.O.: at 5 A (steady), 25 A (inrush)/N.C.: at 20 A (brake) 14 V DC, operating frequency: 0.5s ON, 9.5s OFF
- \*3 At 25A 14 V DC (Motor lock), operating frequency: 0.5s ON, 9.5s OFF
- \*4 Measurement at same location as "Initial breakdown voltage" section
- \*5 Detection current: 10mA
- \*6 Excluding contact bounce time
- \*7 Half-wave pulse of sine wave: 11ms; detection: 10μs
- \*8 Half-wave pulse of sine wave: 6ms

**Characteristics**

|   |   |  |
|---|---|--|
| Max. operating speed<br>(at nominal switching capacity)   | 6 cpm   |  |
| Initial insulation resistance*4   | Min. 100 MΩ (at 500 V DC)   |  |
| Initial breakdown voltage*5   | Between open contacts   | 500 Vrms for 1 min.                                  |
|   | Between contacts and coil   | 500 Vrms for 1 min.                                  |
| Operate time*6<br>(at nominal voltage) (at 20°C 68° F)  | Max. 10ms (Initial)   |  |
| Release time*6<br>(at nominal voltage) (at 20°C 68° F)  | Max. 10ms (Initial)   |  |
| Shock resistance  | Functional*7  | Min. 100 m/s <sup>2</sup> {10G}                      |
|   | Destructive*8   | Min. 1,000 m/s <sup>2</sup> {100G}                   |
| Vibration resistance  | Functional*9  | 10 Hz to 100 Hz,<br>Min. 44.1m/s <sup>2</sup> {4.5G} |
|   | Destructive*10  | 10 Hz to 500 Hz,<br>Min. 44.1m/s <sup>2</sup> {4.5G} |
| Conditions for operation, transport and storage*11 (Not freezing and condensing at low temperature) | Ambient temp  | -40°C to +85°C<br>-40°F to +185°F                    |
|   | Humidity  | 5% R.H. to 85% R.H.                                  |
| Mass  | Approx. 8.0g .28oz (Twin type)<br>Approx. 4.0g .14oz (Slim 1c type) |  |

- \*9 Detection time: 10μs
- \*10 Time of vibration for each direction;  
X, Y, direction: 2 hours  
Z direction: 4 hours



\*11 Refer to 6. CONDITIONS for operation, transport and storage mentioned in AMBIENT ENVIRONMENT

## ORDERING INFORMATION

Ex. A CT 1 12

| Product name | Contact arrangement  | Coil voltage (V DC) |
|--------------|--|---------------------|
| CT           | 1: 1 Form C<br>2: 1 Form C × 2 (8 terminals type)<br>5: 1 Form C × 2 (10 terminals type) | 12: 12              |

Standard packing; 1 Form C: Carton(tube package) 30pcs. Case 1,500pcs.  
1 Form C × 2: Carton(tube package) 30pcs. Case 900pcs.

## TYPES AND COIL DATA (at 20°C 68°F)

| Contact arrangement        | Part No. | Nominal voltage, V DC | Pick-up voltage, V DC (Initial) | Drop-out voltage, V DC (Initial) | Coil resistance, Ω | Nominal operating current, mA | Nominal operating power, mW | Usable voltage range, V DC |
|----------------------------|----------|-----------------------|---------------------------------|----------------------------------|--------------------|-------------------------------|-----------------------------|----------------------------|
| 1c                         | ACT112   | 12                    | Max. 7.2                        | Min. 1.0                         | 180±10%            | 66.7±10%                      | 800                         | 10 to 16                   |
| 1c × 2 (8 terminals type)  | ACT212   | 12                    | Max. 7.2                        | Min. 1.0                         | 180±10%            | 66.7±10%                      | 800                         | 10 to 16                   |
| 1c × 2 (10 terminals type) | ACT512   | 12                    | Max. 7.2                        | Min. 1.0                         | 180±10%            | 66.7±10%                      | 800                         | 10 to 16                   |

\* Other pick-up voltage types are also available. Please contact us for details.

## DIMENSIONS

### 1. Twin type (8 terminals)

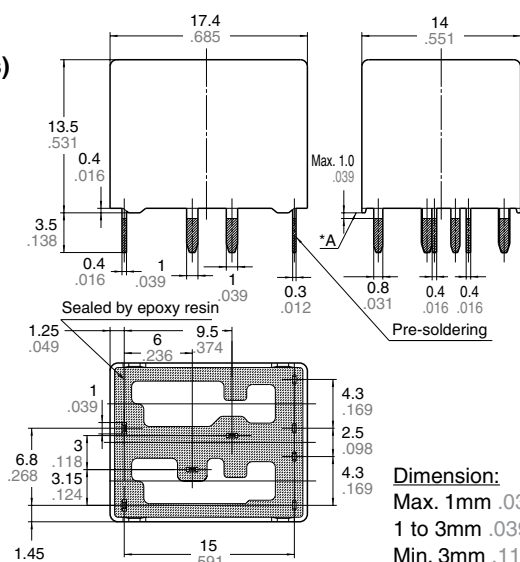

### PC board pattern (Bottom view)

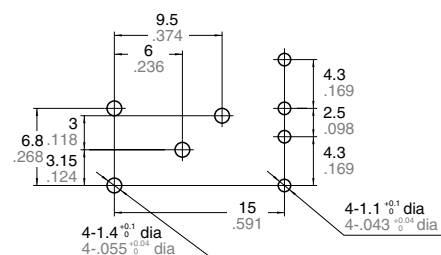

### Schematic (Bottom view)

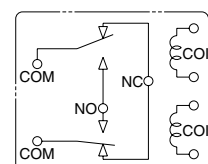

\* Dimensions (thickness and width) of terminal specified in this catalog is measured before pre-soldering. Intervals between terminals is measured at A surface level.

### 2. Twin type (10 terminals)

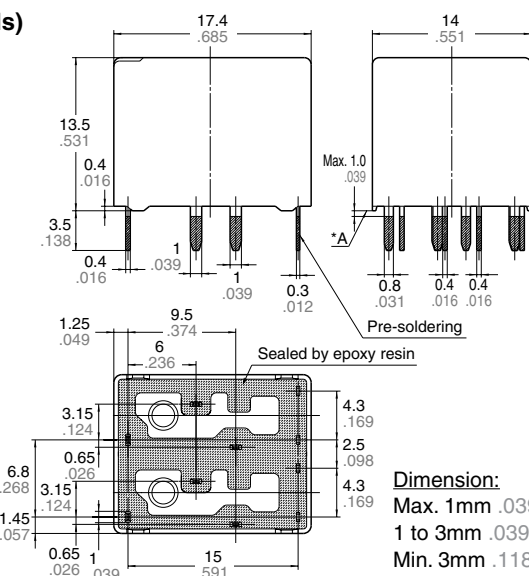

### PC board pattern (Bottom view)

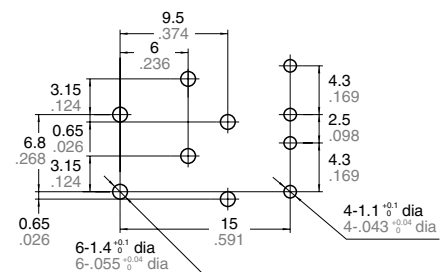

### Schematic (Bottom view)

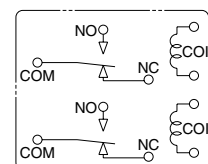

\* Dimensions (thickness and width) of terminal specified in this catalog is measured before pre-soldering. Intervals between terminals is measured at A surface level.

# CT (ACT)

## 3. Slim 1c type

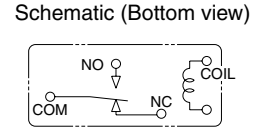
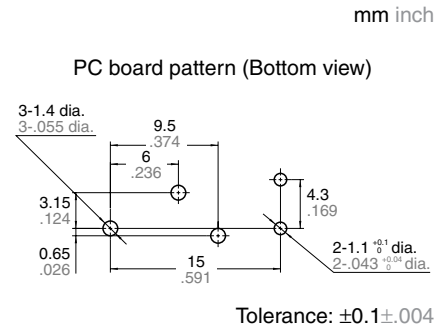
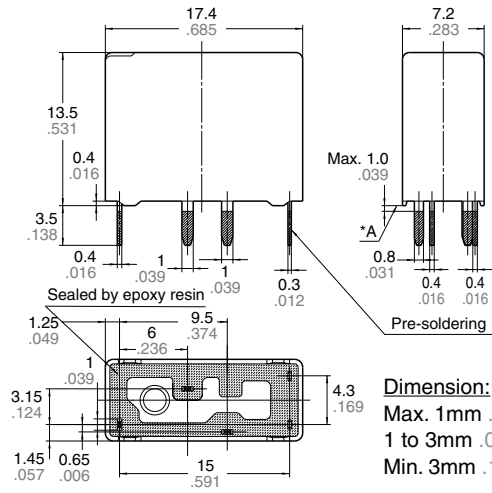

Dimension:

|          |                    |           |                    |
|----------|--------------------|-----------|--------------------|
| Max. 1mm | .039 inch:         | Tolerance | $\pm 0.1 \pm .004$ |
| 1 to 3mm | .039 to .118 inch: |           | $\pm 0.2 \pm .008$ |
| Min. 3mm | .118 inch:         |           | $\pm 0.3 \pm .012$ |

\* Dimensions (thickness and width) of terminal specified in this catalog is measured before pre-soldering. Intervals between terminals is measured at A surface level.

## EXAMPLE OF CIRCUIT

Forward/reverse control circuits of DC motor for power windows

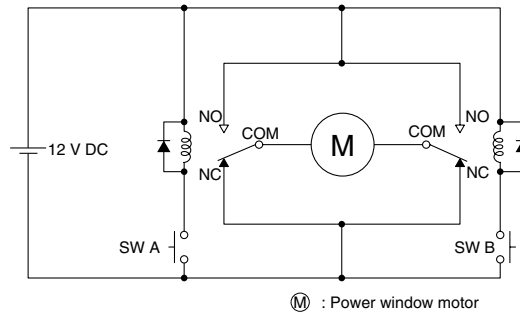

## REFERENCE DATA

1-(1). Coil temperature rise (at room temperature)  
Sample: ACT212, 3pcs.  
Contact carrying current: 0A, 10A, 20A

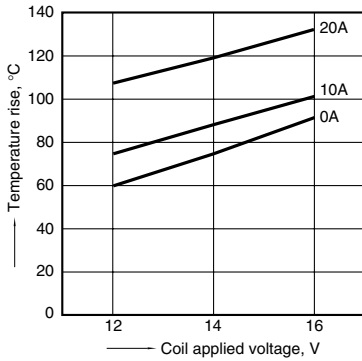

1-(2). Coil temperature rise (at 85°C 185°F)  
Sample: ACT212, 3pcs.  
Contact carrying current: 0A, 10A, 20A

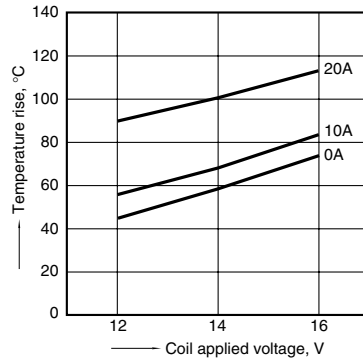

2. Max. switching capability (Resistive load)

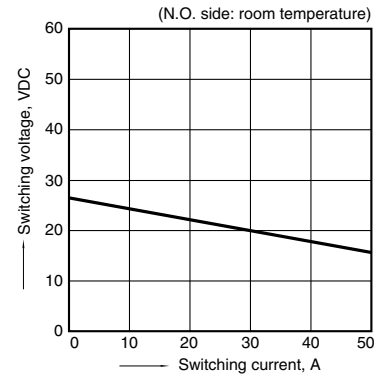

3. Ambient temperature and operating voltage range

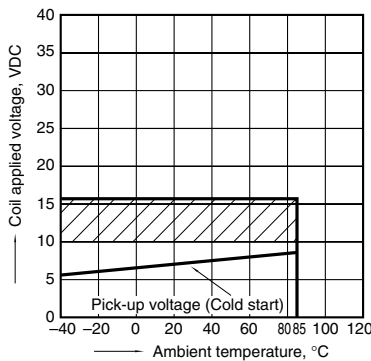

4. Distribution of pick-up and drop-out voltage  
Sample: ACT212, 40pcs.

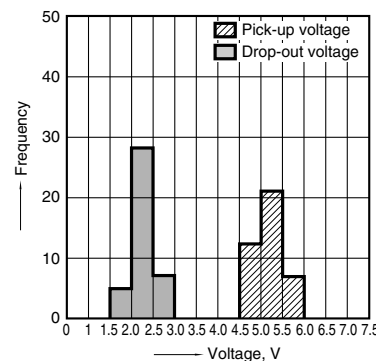

5. Distribution of operate and release time  
Sample: ACT212, 40pcs.  
\* Without diode

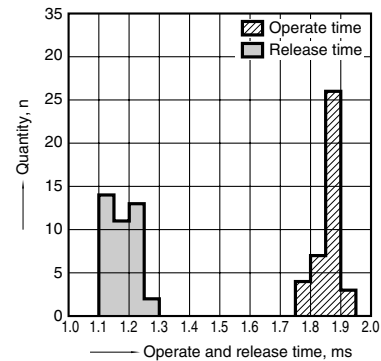

## 6-(1). Electrical life test (Motor free)

Sample: ACT212, 3pcs.  
 Load: 5A steady, Inrush 25A, 14V DC  
 Brake current: 13A 14V DC,  
 Power window motor actual load (free condition)  
 Operating frequency: (ON : OFF = 0.5s : 9.5s)  
 Ambient temperature: Room temperature

Circuit:

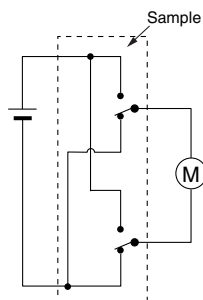

Load current waveform

Inrush current: 25A, Steady current: 6A  
 Brake current: 13A

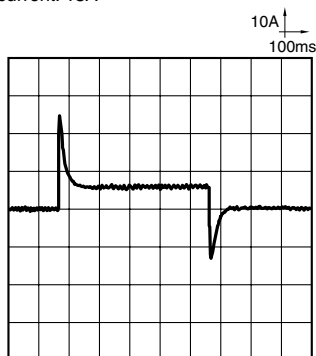

## Change of pick-up and drop-out voltage

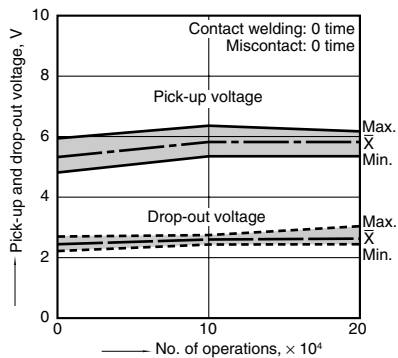

## Change of contact resistance

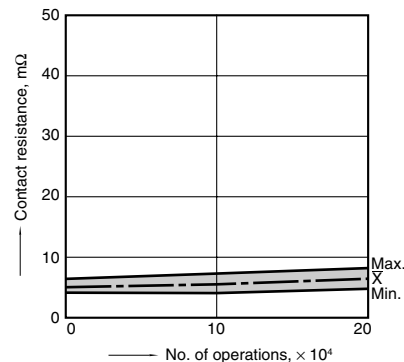

## 6-(2). Electrical life test (Motor lock)

Sample: ACT212, 3pcs.  
 Load: 25A 14V DC  
 Switching frequency: (ON : OFF = 0.5s : 9.5s)  
 Ambient temperature: Room temperature

Circuit:

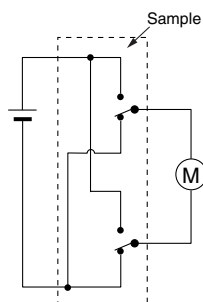

Load current waveform

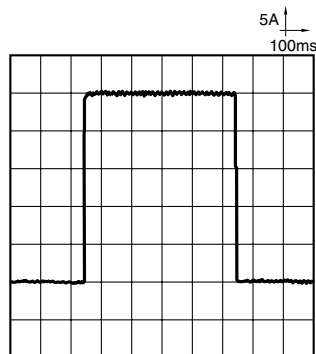

## Change of pick-up and drop-out voltage

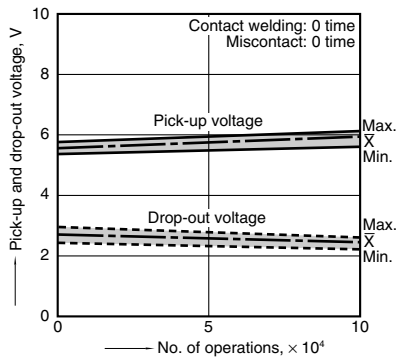

## Change of contact resistance

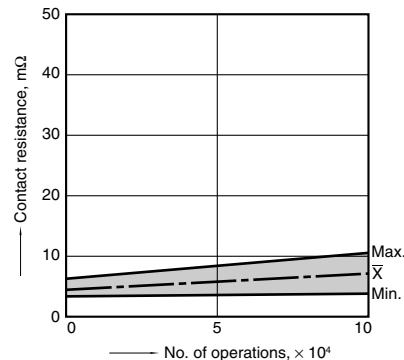

# CT (ACT)

## 6-(3). Electrical life test (Motor lock)

Sample: ACT212, 3pcs.

Load: 20A 14V DC,

door lock motor actual load (Lock condition)

Switching frequency: (ON : OFF = 0.3s : 19.7s)

Ambient temperature: Room temperature

Circuit:

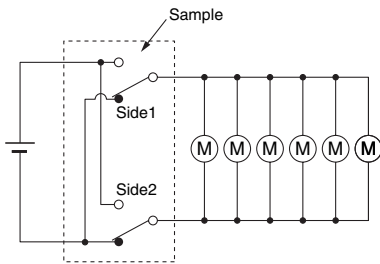

## Change of pick-up and drop-out voltage

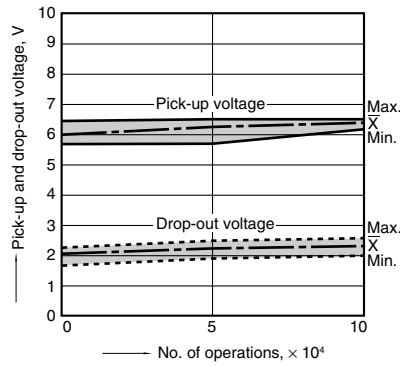

## Change of contact resistance

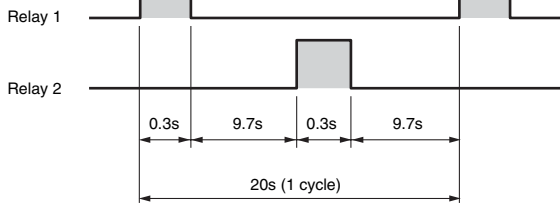
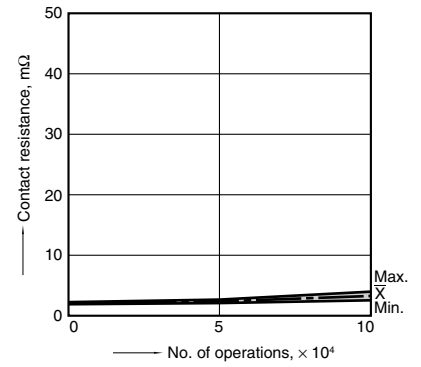

Load current waveform

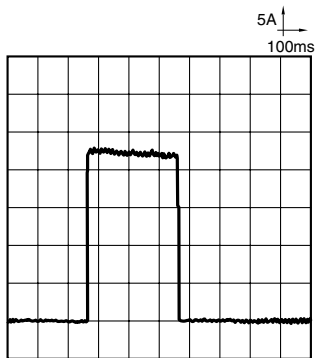

**For Cautions for Use, see Relay Technical Information**