

PC board type

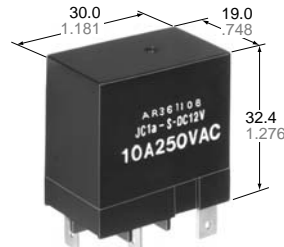

Plug-in type

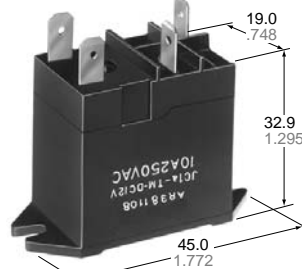

TM type
mm inch

FEATURES

- **High inrush current capability**
1 Form A: 163 A inrush (TV-8)
2 Form A: 111 A inrush (TV-5)
- **High dielectric withstanding for transient protection:**
JC can withstand 10,000 V surge in μ s between coil and contact.
- **Electrical life:**
1 Form A: 10^5 ope. at 15 A 250 V AC resistive load
2 Form A: 10^5 ope. at 10 A 250 V AC resistive load
- **UL/CSA, VDE, TÜV, SEMKO also approved.**

SPECIFICATIONS

Contact

Arrangement	1 Form A	2 Form A		
Initial contact resistance, max. (By voltage drop 6 V DC 1 A)	30 m Ω (Cd free type: 100 m Ω)			
Contact material	Silver alloy			
Contact force, min.	30 g			
Rating (resistive load)	Maximum switching power	3,750 VA	2,500 VA	
	Maximum switching voltage	250 V AC	250 V AC	
	Max. switching current	15 A	10 A	
Expected life (min. operation)	Min. switching capacity ^{#1}	100 mA, 5 V DC		
	Mechanical	5×10^6		
	Electrical (resistive)	15 A 250 V AC	10^5	—
		10 A 250 V AC	—	10^5

Coil

Nominal operating power	900 mW	1,000 mW
-------------------------	--------	----------

^{#1} This value can change due to the switching frequency, environmental conditions, and desired reliability level, therefore it is recommended to check this with the actual load.

Remarks

- * Specifications will vary with foreign standards certification ratings.
- ^{#1} Measurement of same location as "Initial breakdown voltage" section
- ^{#2} Detection current: 10mA
- ^{#3} Excluding contact bounce time
- ^{#4} Half-wave pulse of sine wave: 11ms; detection time: 10 μ s
- ^{#5} Half-wave pulse of sine wave: 6ms
- ^{#6} Detection time: 10 μ s
- ^{#7} Refer to "6. Usage, Storage and Transport Conditions" in [AMBIENT ENVIRONMENT](#) section in [Relay Technical Information](#).

Characteristics

Maximum operating speed	20 cpm.	
Initial insulation resistance ^{*1}	Min. 100 M Ω at 500 V DC	
Initial breakdown voltage ^{*2}	Between open contacts	2,000 V rms for 1 min.
	Between contacts sets	2,000 Vrms for 1 min.
	Between contacts and coil	4,000 Vrms for 1 min.
Operate time ^{*3} (at nominal voltage)	Max. 30 ms	
Release time(without diode) ^{*3} (at nominal voltage)	Max. 10 ms	
Temperature rise (at nominal voltage)	Max. 55°C	
Shock resistance	Functional ^{*4}	196 m/s ² {20 G}
	Destructive ^{*5}	980 m/s ² {100 G}
Vibration resistance	Functional ^{*6}	98 m/s ² {10 G}, 10 to 55 Hz at double amplitude of 1.6 mm
	Destructive	117.6 m/s ² {12 G}, 10 to 55 Hz at double amplitude of 2 mm
Conditions for operation, transport and storage ^{*7} (Not freezing and condensing at low temperature)	Ambient temp.	-50°C to +60°C -58°F to +140°F
	Humidity	5 to 85%R.H.
Unit weight	Approx. 31 g 1.09 oz	

TYPICAL APPLICATIONS

- Automatic garage door openers
- Microwave ovens
- Dryers
- Vending machines
- Copiers
- Air conditioners
- Stereo equipment
- TV sets

ORDERING INFORMATION

Ex. JC 1a F — TM — DC12V — F

Contact arrangement	Mounting classification	Coil voltage	Environmental support
1a: 1 Form A 2a: 2 Form A	Nil: PC board terminal S: Plug-in terminal TM: Top mounting	DC 5, 6, 12, 24, 48 V	F: RoHS Directive conforming type (AgSnO ₂ type)

- (Notes) 1. TV rated types available 1 Form A: TV-8; 2 Form A: TV-5.
2. Standard packing. Carton: 50 pcs.; Case: 200 pcs.
3. UL/CSA, VDE, TÜV, and SEMKO certified products can also be supported. Please consult us.

COIL DATA (at 20°C 68°F)

Contact arrangement	Nominal voltage, V DC	Pick-up voltage, V DC (max.)	Drop-out voltage, V DC (min.)	Coil resistance, Ω(±10%)	Nominal operating current, mA	Nominal operating power, W	Maximum allowable voltage, V DC (at 60°C)
1 Form A	6	4.8	0.6	40	150	0.9	6.6
	12	9.6	1.2	160	75	0.9	13.2
	24	19.2	2.4	640	37.5	0.9	26.4
	48	38.4	4.8	2,560	18.8	0.9	52.8
2 Form A	6	4.8	0.6	36	166.6	1.0	6.6
	12	9.6	1.2	144	83.3	1.0	13.2
	24	19.2	2.4	576	41.6	1.0	26.4
	48	38.4	4.8	2,304	20.8	1.0	52.8

DIMENSIONS

mm inch

**PC board type
JC1a**

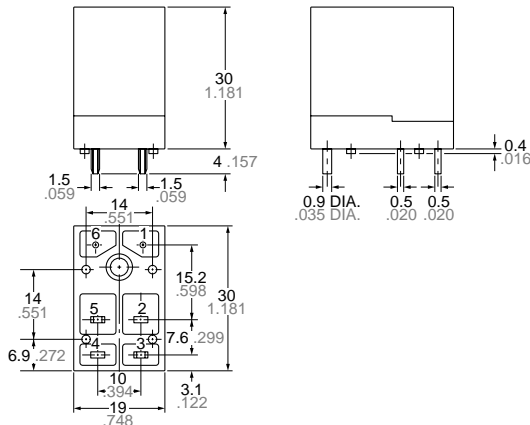

Schematic

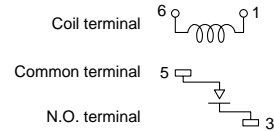

PC board pattern (Bottom view)

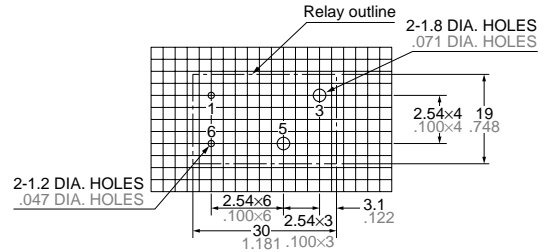

**PC board type
JC2a**

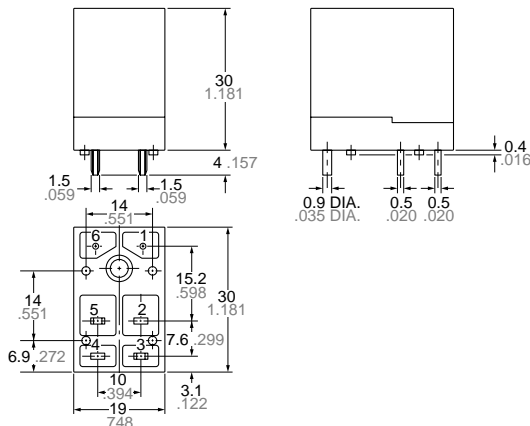

Schematic

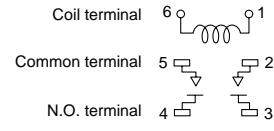

PC board pattern (Bottom view)

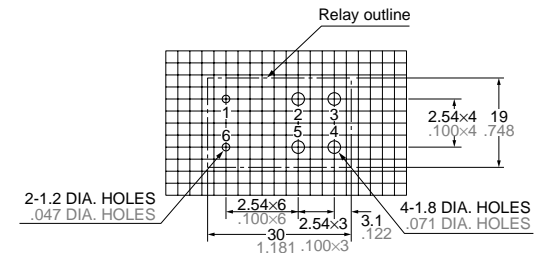

General tolerance: ±0.3 ±.012

Tolerance: ±0.1 ±.004

Top mount type

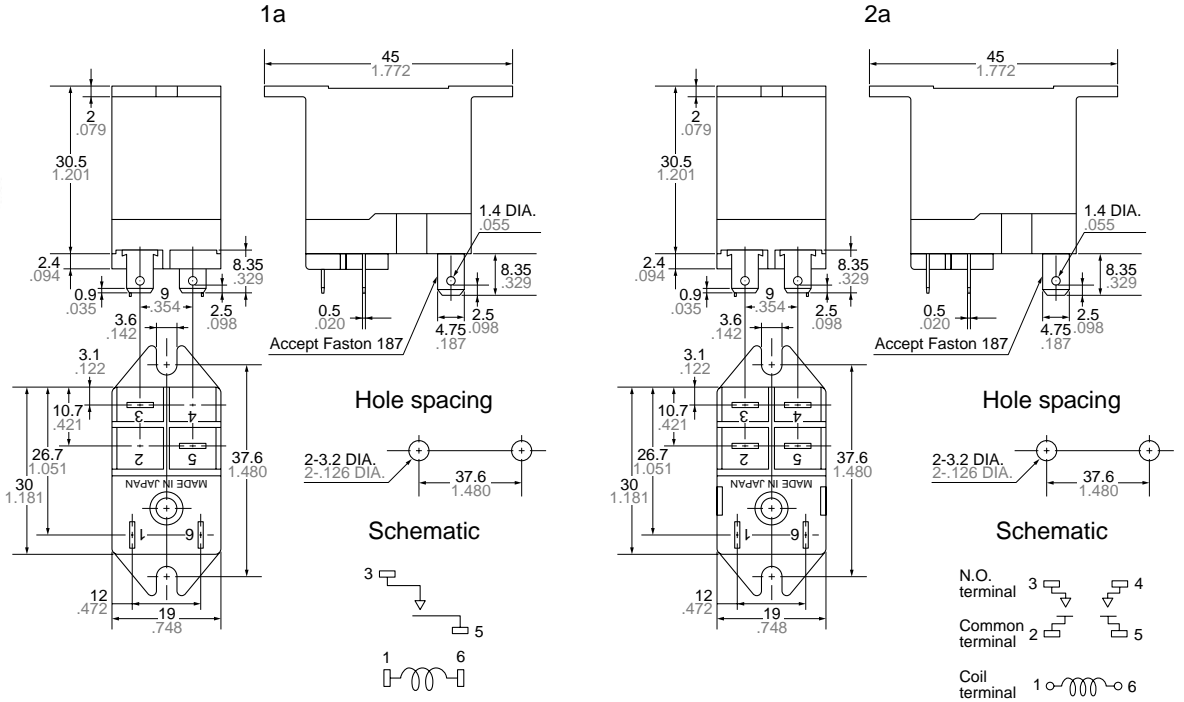

Plug-in type

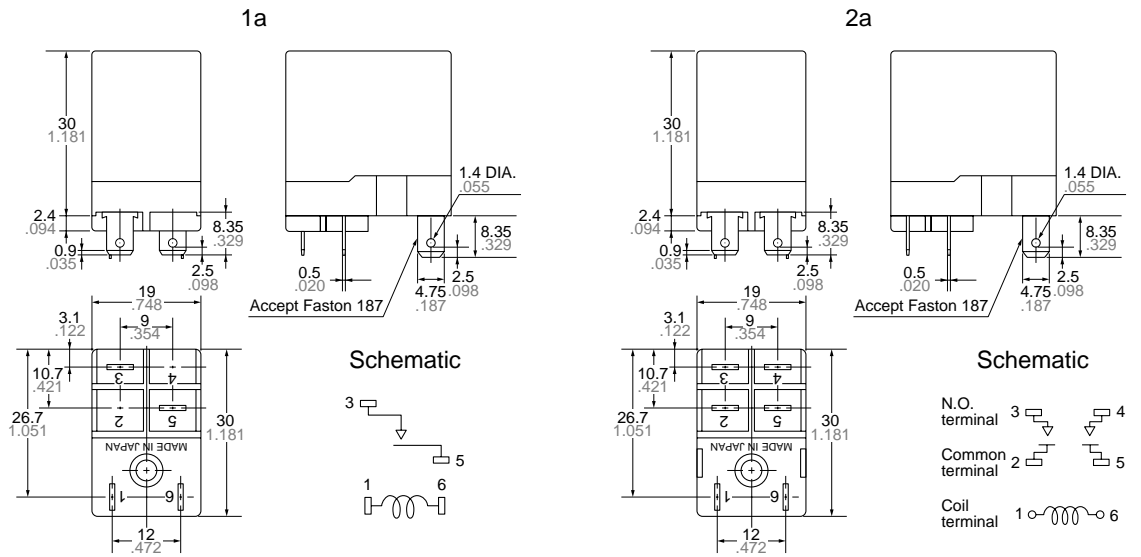

General tolerance: $\pm 0.3 \pm 0.12$

REFERENCE DATA

JC1a type

1. Maximum value for switching capacity

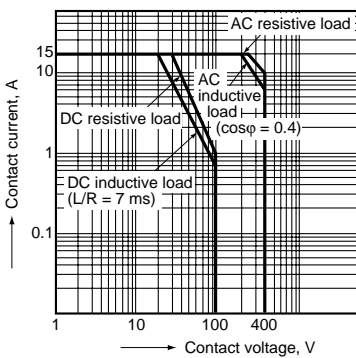

2. Life curve

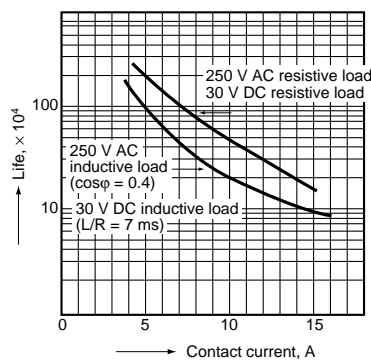

3.-1) Coil temperature rise

Point measured: Inside the coil
Ambient temperature: 26°C 79°F

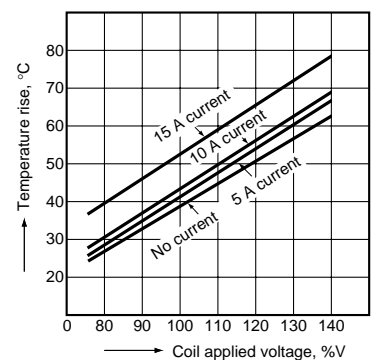

3.-(2) Coil temperature rise
 Point measured: Inside the coil
 Ambient temperature: 40°C 104°F

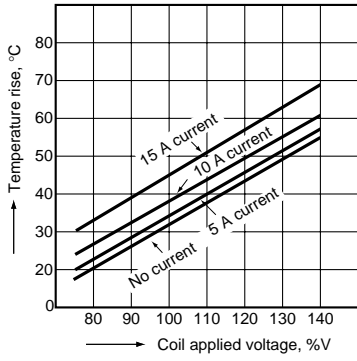

3.-(3) Coil temperature rise
 Point measured: Inside the coil
 Ambient temperature: 60°C 140°F

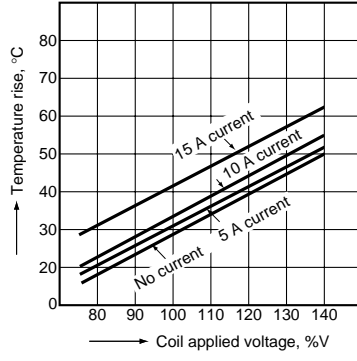

4. Operate / release time

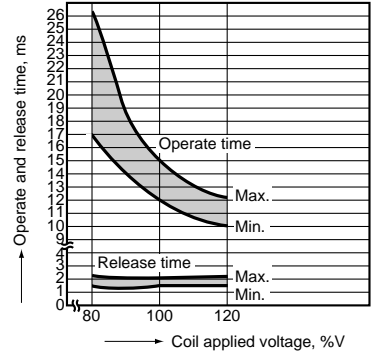

JC2a type

1. Maximum value for switching capacity

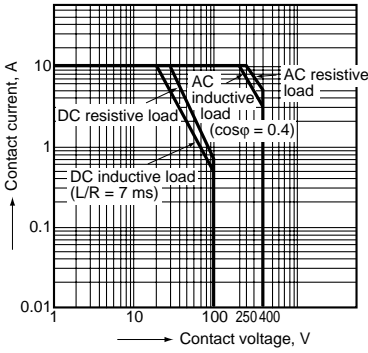

2. Life curve

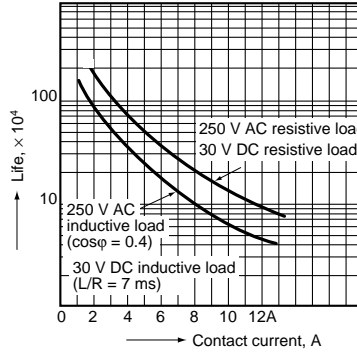

3.-(1) Coil temperature rise

Point measured: Inside the coil
 Ambient temperature: 26°C 79°F

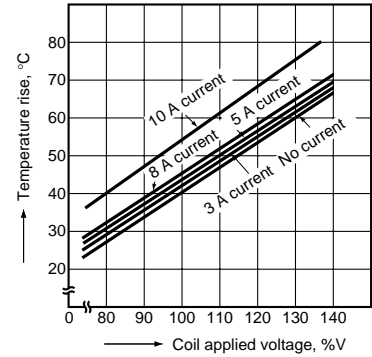

3.-(2) Coil temperature rise
 Point measured: Inside the coil
 Ambient temperature: 40°C 104°F

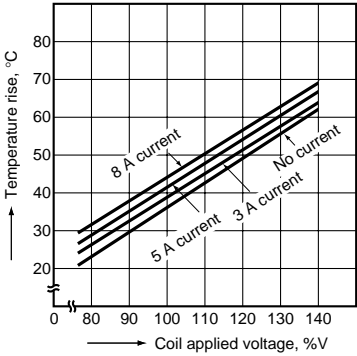

3.-(3) Coil temperature rise
 Point measured: Inside the coil
 Ambient temperature: 60°C 140°F

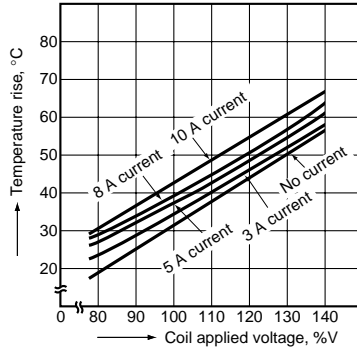

4. Operate / release time

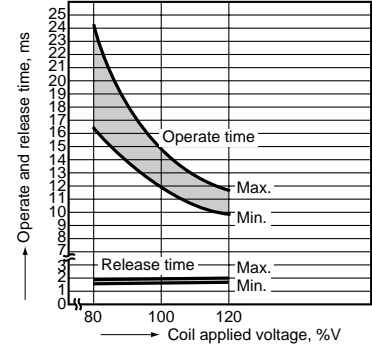

For Cautions for Use, see [Relay Technical Information](#).

ACCESSORIES



JC1-SS



JC2-SS



JC1-PS



JC2-PS

JC2-SS

JC2-PS

mm inch

Tolerance: $\pm 0.5 \pm .020$

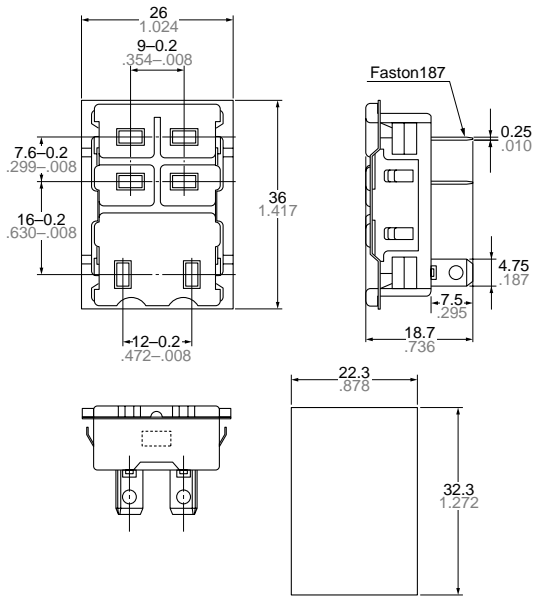

Panel cutout
Tolerance: $\pm 0.1 \pm .004$

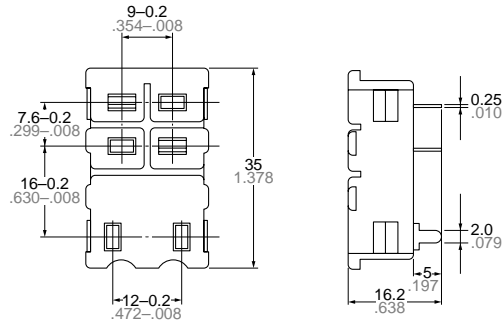

JC1-PS

JC2-PS

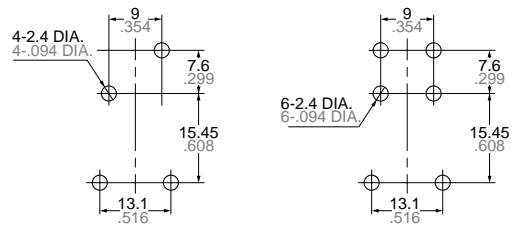

PC board Pattern

Tolerance: $\pm 0.1 \pm .004$

(Note)

Outward dimensions and chassis cutout dimensions for JC1-SS and JC1-PS are same as those of JC2-SS and JC2-PS respectively.
UL/CSA approved type is standard.

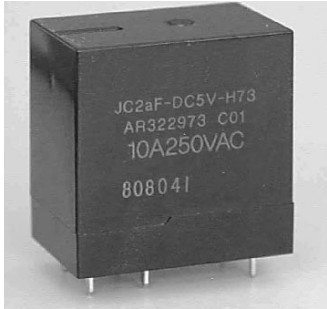

Data sheet addition for JC Relay

- Integrated arc-blowing magnet for high DC loads [H73 type]
- High switching capacity: 20A/60V DC
- Clearance and creepage distance contact/coil: 8 mm
- Two contacts connected in series ensures even higher life expectancy

APPLICATIONS: Switching of DC loads in devices such as
 - Control of Industrial DC motors
 - Emergency power-off for DC loads

Arrangement		2 Form A	
Contact material		AgSnO ₂	
Contact connection		one contact	two contacts in series
Rating (resistive) load	250VDC / 5A	1 × 10 ⁴ ops.	2 × 10 ⁴ ops.
	250VDC / 4A	3 × 10 ⁴ ops.	4 × 10 ⁴ ops.
Special loads test data (min. operations at 20°C)	220VDC / 1,6A; L/R = 14.6ms (1s On, 4s Off)	2 × 10 ⁴	3 × 10 ⁴
	220VDC / 1A; L/R = 17.4ms (1s On, 4s Off)	2 × 10 ⁴	3 × 10 ⁴
	60VDC / 20A; resistive load (30s On, 30s Off)	1 × 10 ⁴	2 × 10 ⁴

Mechanical, endurance and coil data according to JC-datasheet

Load limit curve for connection in series

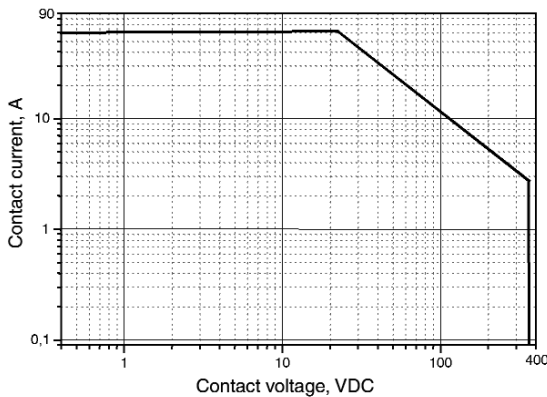

Connection diagram

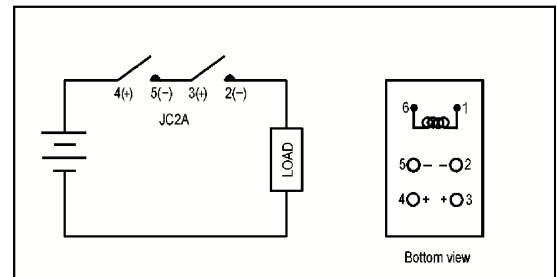

Attention: For the Blow-out effect, the polarity must be defined as: (-) at contacts: 2, 5
 (+) at contacts: 3, 4

ORDERING AND TYPE INFORMATION (values at 20°C)

Type	Nominal voltage, V DC	Pick-up voltage, V DC (max.)	Drop-out voltage, V DC (min.)	Nominal operating power, W	Coil resistance, Ω (±10%)
JC2aF-DC5V-Y1-F-H73	5	4.0	0.5	1	25
JC2aF-DC6V-Y1-F-H73	6	4.8	0.6	1	36
JC2aF-DC12V-Y1-F-H73	12	9.6	1.2	1	144
JC2aF-DC24V-Y1-F-H73	24	19.2	2.4	1	576
JC2aF-DC48V-Y1-F-H73	48	38.4	4.8	1	2304