

# KEMET CONDUCTIVE POLYMER CHIP CAPACITORS

CHARGED™

## T520 Series - KO Cap

### FEATURES

- Polymer Cathode Technology
- Low ESR
- High Frequency Cap Retention
- No-Ignition Failure Mode
- Use Up to 90% of Rated Voltage (10% Derating) for part types ≤ 10 Volts
- Halogen Free Epoxy
- 100% Accelerated Steady State Aging
- Volumetrically Efficient
- Use Up to 80% of Rated Voltage (20% Derating) for part types > 10 Volts
- Capacitance 15 to 1000µF (±20%)
- Voltage 2V to 25V
- EIA Standard Case Sizes
- 100% Surge Current Tested
- Operating Temperature -55°C to +105°C
- Self Healing Mechanism
- RoHS Compliant & Leadfree Terminations (see [www.kemet.com](http://www.kemet.com) for lead transition)

### OUTLINE DRAWING

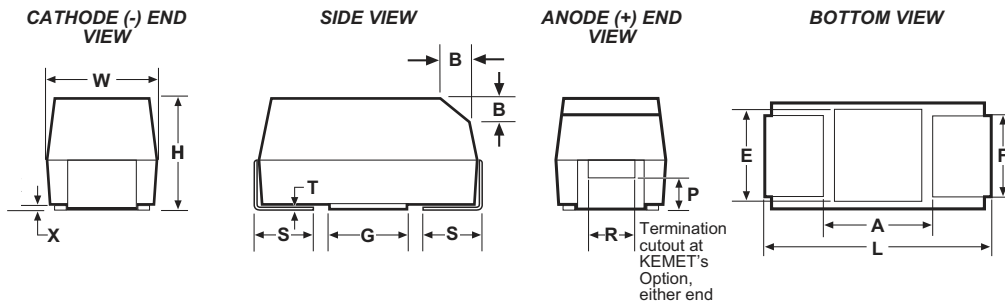

### DIMENSIONS - MILLIMETERS

| Case Size |         | L         | W         | H         | F ± 0.1 | S ± 0.3 | X(Ref)      | T(Ref) | A(Min) | G(ref) | E(ref) |
|-----------|---------|-----------|-----------|-----------|---------|---------|-------------|--------|--------|--------|--------|
| KEMET     | EIA     |           |           |           |         |         |             |        |        |        |        |
| A         | 3216-18 | 3.2 ± 0.2 | 1.6 ± 0.2 | 1.6 ± 0.2 | 1.2     | 0.8     | 0.10 ± 0.10 | 0.13   | 0.8    | 1.1    | 1.3    |
| T         | 3528-12 | 3.5 ± 0.2 | 2.8 ± 0.2 | 1.2 max   | 2.2     | 0.8     | 0.05        | 0.13   | 1.1    | 1.8    | 2.2    |
| M         | 3528-15 | 3.5 ± 0.2 | 2.8 ± 0.2 | 1.5 max   | 2.2     | 0.8     | 0.11        | 0.13   | 2.1    | 1.8    | 2.2    |
| B         | 3528-21 | 3.5 ± 0.2 | 2.8 ± 0.2 | 1.9 ± 0.1 | 2.2     | 0.8     | 0.10 ± 0.10 | 0.13   | 1.1    | 1.8    | 2.2    |
| U         | 6032-15 | 6.0 ± 0.3 | 3.2 ± 0.3 | 1.5 max   | 2.2     | 1.3     | 0.05        | 0.13   | 3.1    | 2.8    | 2.4    |
| L         | 6032-19 | 6.0 ± 0.3 | 3.2 ± 0.3 | 1.9 max   | 2.2     | 1.3     | 0.10 ± 0.10 | 0.13   | 2.5    | 2.8    | 2.4    |
| C         | 6032-28 | 6.0 ± 0.3 | 3.2 ± 0.3 | 2.5 ± 0.3 | 2.2     | 1.3     | 0.10 ± 0.10 | 0.13   | 2.5    | 2.8    | 2.4    |
| W         | 7343-15 | 7.3 ± 0.3 | 4.3 ± 0.3 | 1.5 max   | 2.4     | 1.3     | 0.05        | 0.13   | 3.8    | 3.5    | 3.5    |
| V         | 7343-20 | 7.3 ± 0.3 | 4.3 ± 0.3 | 1.9 max   | 2.4     | 1.3     | 0.05        | 0.13   | 3.8    | 3.5    | 3.5    |
| D         | 7343-31 | 7.3 ± 0.3 | 4.3 ± 0.3 | 2.8 ± 0.3 | 2.4     | 1.3     | 0.10 ± 0.10 | 0.13   | 3.8    | 3.5    | 3.5    |
| Y         | 7343-40 | 7.3 ± 0.3 | 4.3 ± 0.3 | 4.0 max   | 2.4     | 1.3     | 0.10 ± 0.10 | 0.13   | 3.8    | 3.5    | 3.5    |
| X         | 7343-43 | 7.3 ± 0.3 | 4.3 ± 0.3 | 4.0 ± 0.3 | 2.4     | 1.3     | 0.10 ± 0.10 | 0.13   | 3.8    | 3.5    | 3.5    |

### T520 ORDERING INFORMATION

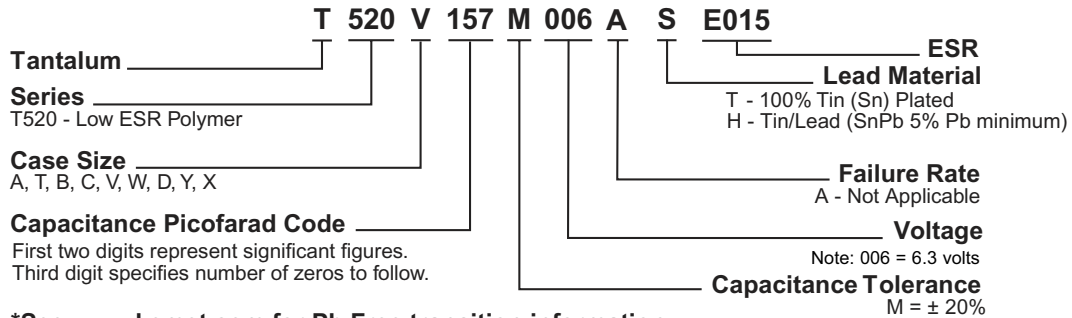

\*See [www.kemet.com](http://www.kemet.com) for Pb Free transition information.

### COMPONENT MARKING

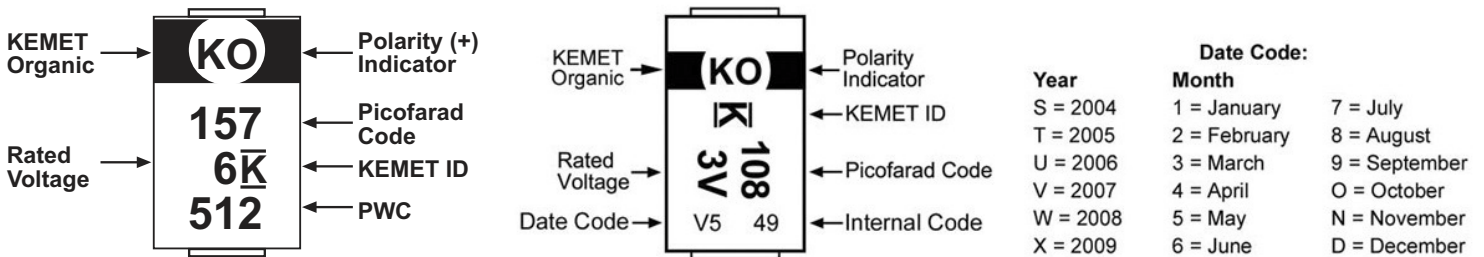

512 = 12th week of 2005

# CONDUCTIVE POLYMER CHIP CAPACITORS

## T520 Series - KO Cap



### T520 RATINGS & PART NUMBER REFERENCE

| Capacitance $\mu$ F            | Case Size | KEMET Part Number    | DC Leakage $\mu$ A @ 25°C Max | DF% @ 25°C 120 Hz Max | ESR m $\Omega$ @ 25°C 100 kHz Max | Ripple Current Arms @ 100 kHz Max  |                            |
|--------------------------------|-----------|----------------------|-------------------------------|-----------------------|-----------------------------------|------------------------------------|----------------------------|
|                                |           |                      |                               |                       |                                   | w/ $\Delta$ T=20°C @ -55°C to 85°C | w/ $\Delta$ T= 2°C @ 105°C |
| <b>2 Volt Rating @ 105°C</b>   |           |                      |                               |                       |                                   |                                    |                            |
| 470.0                          | V         | T520V477M002A(1)E040 | 94                            | 10                    | 40                                | 1.8                                | 0.6                        |
| <b>2.5 Volt Rating @ 105°C</b> |           |                      |                               |                       |                                   |                                    |                            |
| 47.0                           | A         | T520A476M2R5A(1)E090 | 12                            | 8                     | 90                                | 0.9                                | 0.3                        |
| 56.0                           | T         | T520T568M2R5A(1)E040 | 14                            | 8                     | 40                                | 1.3                                | 0.4                        |
| 56.0                           | T         | T520T568M2R5A(1)E070 | 14                            | 8                     | 70                                | 1.0                                | 0.3                        |
| 68.0                           | A         | T520A686M2R5A(1)E070 | 17                            | 8                     | 70                                | 1.0                                | 0.3                        |
| 68.0                           | A         | T520A686M2R5A(1)E080 | 17                            | 8                     | 80                                | 1.0                                | 0.3                        |
| 100.0                          | T         | T520T107M2R5A(1)E070 | 25                            | 8                     | 70                                | 1.0                                | 0.3                        |
| 100.0                          | B         | T520B107M2R5A(1)E025 | 25                            | 8                     | 25                                | 1.8                                | 0.6                        |
| 100.0                          | B         | T520B107M2R5A(1)E035 | 25                            | 8                     | 35                                | 1.6                                | 0.5                        |
| 100.0                          | B         | T520B107M2R5A(1)E040 | 25                            | 8                     | 40                                | 1.5                                | 0.5                        |
| 100.0                          | B         | T520B107M2R5A(1)E070 | 25                            | 8                     | 70                                | 1.1                                | 0.3                        |
| 150.0                          | U         | T520U157M2R5A(1)E055 | 38                            | 8                     | 55                                | 1.3                                | 0.4                        |
| 220.0                          | B         | T520B227M2R5A(1)E025 | 55                            | 8                     | 25                                | 1.8                                | 0.6                        |
| 220.0                          | B         | T520B227M2R5A(1)E030 | 55                            | 8                     | 30                                | 1.7                                | 0.5                        |
| 220.0                          | B         | T520B227M2R5A(1)E035 | 55                            | 8                     | 35                                | 1.6                                | 0.5                        |
| 220.0                          | B         | T520B227M2R5A(1)E070 | 55                            | 8                     | 70                                | 1.1                                | 0.3                        |
| 220.0                          | C         | T520C227M2R5A(1)E025 | 55                            | 8                     | 25                                | 2.1                                | 0.7                        |
| 220.0                          | C         | T520C227M2R5A(1)E045 | 55                            | 8                     | 45                                | 1.6                                | 0.5                        |
| 220.0                          | V         | T520V227M2R5A(1)E007 | 55                            | 10                    | 7                                 | 4.2                                | 1.3                        |
| 220.0                          | V         | T520V227M2R5A(1)E009 | 55                            | 10                    | 9                                 | 3.7                                | 1.2                        |
| 220.0                          | V         | T520V227M2R5A(1)E012 | 55                            | 10                    | 12                                | 3.2                                | 1.0                        |
| 220.0                          | V         | T520V227M2R5A(1)E015 | 55                            | 10                    | 15                                | 2.9                                | 0.9                        |
| 220.0                          | V         | T520V227M2R5A(1)E025 | 55                            | 10                    | 25                                | 2.2                                | 0.7                        |
| 220.0                          | V         | T520V227M2R5A(1)E045 | 55                            | 10                    | 45                                | 1.7                                | 0.5                        |
| 220.0                          | D         | T520D227M2R5A(1)E007 | 55                            | 10                    | 7                                 | 4.6                                | 1.5                        |
| 220.0                          | D         | T520D227M2R5A(1)E040 | 55                            | 10                    | 40                                | 1.9                                | 0.6                        |
| 330.0                          | B         | T520B337M2R5A(1)E045 | 83                            | 8                     | 45                                | 1.4                                | 0.4                        |
| 330.0                          | B         | T520B337M2R5A(1)E070 | 83                            | 8                     | 70                                | 1.1                                | 0.3                        |
| 330.0                          | C         | T520C337M2R5A(1)E015 | 83                            | 8                     | 15                                | 2.7                                | 0.8                        |
| 330.0                          | C         | T520C337M2R5A(1)E018 | 83                            | 8                     | 18                                | 2.4                                | 0.8                        |
| 330.0                          | C         | T520C337M2R5A(1)E025 | 83                            | 8                     | 25                                | 2.1                                | 0.7                        |
| 330.0                          | C         | T520C337M2R5A(1)E045 | 83                            | 8                     | 45                                | 1.6                                | 0.5                        |
| 330.0                          | L         | T520L337M2R5A(1)E012 | 83                            | 10                    | 12                                | 2.9                                | 0.9                        |
| 330.0                          | L         | T520L337M2R5A(1)E025 | 83                            | 10                    | 25                                | 2.0                                | 0.6                        |
| 330.0                          | W         | T520W337M2R5A(1)E040 | 83                            | 10                    | 40                                | 1.7                                | 0.5                        |
| 330.0                          | V         | T520V337M2R5A(1)E006 | 83                            | 10                    | 6                                 | 4.6                                | 1.4                        |
| 330.0                          | V         | T520V337M2R5A(1)E007 | 83                            | 10                    | 7                                 | 4.2                                | 1.3                        |
| 330.0                          | V         | T520V337M2R5A(1)E009 | 83                            | 10                    | 9                                 | 3.7                                | 1.2                        |
| 330.0                          | V         | T520V337M2R5A(1)E012 | 83                            | 10                    | 12                                | 3.2                                | 1.0                        |
| 330.0                          | V         | T520V337M2R5A(1)E015 | 83                            | 10                    | 15                                | 2.9                                | 0.9                        |
| 330.0                          | V         | T520V337M2R5A(1)E018 | 83                            | 10                    | 18                                | 2.6                                | 0.8                        |
| 330.0                          | V         | T520V337M2R5A(1)E025 | 83                            | 10                    | 25                                | 2.2                                | 0.7                        |
| 330.0                          | V         | T520V337M2R5A(1)E040 | 83                            | 10                    | 40                                | 1.8                                | 0.6                        |
| 330.0                          | D         | T520D337M2R5A(1)E006 | 83                            | 10                    | 6                                 | 5.0                                | 1.7                        |
| 330.0                          | D         | T520D337M2R5A(1)E007 | 83                            | 10                    | 7                                 | 4.6                                | 1.5                        |
| 470.0                          | V         | T520V477M2R5A(1)E007 | 118                           | 10                    | 7                                 | 4.2                                | 1.3                        |
| 470.0                          | V         | T520V477M2R5A(1)E009 | 118                           | 10                    | 9                                 | 3.7                                | 1.2                        |
| 470.0                          | V         | T520V477M2R5A(1)E012 | 118                           | 10                    | 12                                | 3.2                                | 1.0                        |
| 470.0                          | V         | T520V477M2R5A(1)E015 | 118                           | 10                    | 15                                | 2.9                                | 0.9                        |
| 470.0                          | V         | T520V477M2R5A(1)E018 | 118                           | 10                    | 18                                | 2.6                                | 0.8                        |
| 470.0                          | C         | T520C477M2R5A(1)E025 | 118                           | 8                     | 25                                | 2.0                                | 0.6                        |
| 470.0                          | C         | T520C477M2R5A(1)E045 | 118                           | 8                     | 45                                | 1.5                                | 0.5                        |
| 470.0                          | D         | T520D477M2R5A(1)E006 | 118                           | 10                    | 6                                 | 5.0                                | 1.7                        |
| 470.0                          | D         | T520D477M2R5A(1)E007 | 118                           | 10                    | 7                                 | 4.6                                | 1.5                        |
| 470.0                          | D         | T520D477M2R5A(1)E009 | 118                           | 10                    | 9                                 | 4.1                                | 1.3                        |
| 680.0                          | D         | T520D687M2R5A(1)E010 | 170                           | 10                    | 10                                | 3.9                                | 1.2                        |
| 680.0                          | D         | T520D687M2R5A(1)E015 | 170                           | 10                    | 15                                | 3.2                                | 1.0                        |
| 680.0                          | D         | T520D687M2R5A(1)E040 | 170                           | 10                    | 40                                | 1.9                                | 0.6                        |
| 680.0                          | Y         | T520Y687M2R5A(1)E015 | 170                           | 10                    | 15                                | 3.3                                | 1.0                        |
| 680.0                          | Y         | T520Y687M2R5A(1)E025 | 170                           | 10                    | 25                                | 2.5                                | 0.8                        |
| 1000.0                         | D         | T520D108M2R5A(1)E015 | 250                           | 8                     | 15                                | 3.2                                | 1.1                        |
| 1000.0                         | D         | T520D108M2R5A(1)E030 | 250                           | 10                    | 30                                | 2.2                                | 0.7                        |
| 1000.0                         | Y         | T520Y108M2R5A(1)E010 | 250                           | 10                    | 10                                | 4.0                                | 1.3                        |
| 1000.0                         | Y         | T520Y108M2R5A(1)E015 | 250                           | 10                    | 15                                | 3.3                                | 1.0                        |
| 1000.0                         | Y         | T520Y108M2R5A(1)E025 | 250                           | 10                    | 25                                | 2.5                                | 0.8                        |
| 1000.0                         | X         | T520X108M2R5A(1)E010 | 250                           | 10                    | 10                                | 4.1                                | 1.3                        |
| <b>3 Volt Rating @ 105°C</b>   |           |                      |                               |                       |                                   |                                    |                            |
| 100.0                          | B         | T520B107M003A(1)E025 | 30                            | 8                     | 25                                | 1.8                                | 0.6                        |
| 100.0                          | B         | T520B107M003A(1)E035 | 30                            | 8                     | 35                                | 1.6                                | 0.5                        |
| 100.0                          | B         | T520B107M003A(1)E040 | 30                            | 8                     | 40                                | 1.5                                | 0.5                        |
| 100.0                          | B         | T520B107M003A(1)E070 | 30                            | 8                     | 70                                | 1.1                                | 0.3                        |
| 150.0                          | B         | T520B157M003A(1)E035 | 45                            | 8                     | 35                                | 1.6                                | 0.5                        |
| 150.0                          | B         | T520B157M003A(1)E040 | 45                            | 8                     | 40                                | 1.5                                | 0.5                        |
| 150.0                          | B         | T520B157M003A(1)E070 | 45                            | 8                     | 70                                | 1.1                                | 0.3                        |
| 330.0                          | V         | T520V337M003A(1)E009 | 99                            | 10                    | 9                                 | 3.7                                | 1.2                        |
| 330.0                          | V         | T520V337M003A(1)E012 | 99                            | 10                    | 12                                | 3.2                                | 1.0                        |
| 330.0                          | V         | T520V337M003A(1)E015 | 99                            | 10                    | 15                                | 2.9                                | 0.9                        |
| 330.0                          | V         | T520V337M003A(1)E025 | 99                            | 10                    | 25                                | 2.2                                | 0.7                        |
| 680.0                          | D         | T520D687M003A(1)E015 | 204                           | 10                    | 15                                | 3.2                                | 1.0                        |
| 680.0                          | D         | T520D687M003A(1)E040 | 204                           | 10                    | 40                                | 1.9                                | 0.6                        |
| 1000.0                         | X         | T520X108M003A(1)E015 | 300                           | 10                    | 15                                | 3.3                                | 1.0                        |
| 1000.0                         | X         | T520X108M003A(1)E030 | 300                           | 10                    | 30                                | 2.3                                | 0.7                        |
| <b>4 Volt Rating @ 105°C</b>   |           |                      |                               |                       |                                   |                                    |                            |
| 15.0                           | T         | T520T156M004A(1)E100 | 6                             | 8                     | 100                               | 0.8                                | 0.3                        |
| 33.0                           | A         | T520A336M004A(1)E070 | 13                            | 8                     | 70                                | 1.0                                | 0.3                        |
| 33.0                           | A         | T520A336M004A(1)E080 | 13                            | 8                     | 80                                | 1.0                                | 0.3                        |
| 47.0                           | A         | T520A476M004A(1)E070 | 19                            | 8                     | 70                                | 1.0                                | 0.3                        |
| 47.0                           | A         | T520A476M004A(1)E080 | 19                            | 8                     | 80                                | 1.0                                | 0.3                        |
| 47.0                           | T         | T520T476M004A(1)E070 | 19                            | 8                     | 70                                | 1.0                                | 0.3                        |
| 68.0                           | T         | T520T686M004A(1)E070 | 27                            | 8                     | 70                                | 1.0                                | 0.3                        |
| 68.0                           | B         | T520B686M004A(1)E025 | 27                            | 8                     | 25                                | 1.8                                | 0.6                        |
| 68.0                           | B         | T520B686M004A(1)E035 | 27                            | 8                     | 35                                | 1.6                                | 0.5                        |
| 68.0                           | B         | T520B686M004A(1)E040 | 27                            | 8                     | 40                                | 1.5                                | 0.5                        |
| 68.0                           | B         | T520B686M004A(1)E070 | 27                            | 8                     | 70                                | 1.1                                | 0.3                        |
| 68.0                           | U         | T520U686M004A(1)E055 | 27                            | 8                     | 55                                | 1.3                                | 0.4                        |
| 100.0                          | B         | T520B107M004A(1)E025 | 40                            | 8                     | 25                                | 1.8                                | 0.6                        |
| 100.0                          | B         | T520B107M004A(1)E035 | 40                            | 8                     | 35                                | 1.6                                | 0.5                        |
| 100.0                          | B         | T520B107M004A(1)E040 | 40                            | 8                     | 40                                | 1.5                                | 0.5                        |
| 100.0                          | B         | T520B107M004A(1)E070 | 40                            | 8                     | 70                                | 1.1                                | 0.3                        |
| 100.0                          | U         | T520U107M004A(1)E055 | 40                            | 8                     | 55                                | 1.3                                | 0.4                        |

(1) To complete KEMET part number, insert letter designation for lead material from page 50. Higher voltage ratings and tighter tolerance product may be substituted with the same size as KEMET's option. Voltage substitutions will be marked with the higher voltage rating.

Conductive Polymer Surface Mount



# CONDUCTIVE POLYMER CHIP CAPACITORS

## T520 Series - KO Cap

### T520 RATINGS & PART NUMBER REFERENCE

| Capacitance $\mu\text{F}$          | Case Size | KEMET Part Number    | DC Leakage $\mu\text{A}$ @ 25°C Max | DF% @ 25°C 120 Hz Max | ESR $\text{m}\Omega$ @ 25°C 100 kHz Max | Ripple Current Arms @ 100 kHz Max |                   |
|------------------------------------|-----------|----------------------|-------------------------------------|-----------------------|---|-----------------------------------|-------------------|
|                                    |           |                      |                                     |                       |   | w/ΔT=20°C @ -55°C to 85°C         | w/ΔT= 2°C @ 105°C |
| <b>4 Volt Rating @ 105°C cont.</b> |           |                      |                                     |                       |   |                                   |                   |
| 150.0                              | B         | T520B157M004A(1)E035 | 60                                  | 8                     | 35                                      | 1.6                               | 0.5               |
| 150.0                              | B         | T520B157M004A(1)E040 | 60                                  | 8                     | 40                                      | 1.5                               | 0.5               |
| 150.0                              | B         | T520B157M004A(1)E070 | 60                                  | 8                     | 70                                      | 1.1                               | 0.3               |
| 150.0                              | U         | T520U157M004A(1)E055 | 60                                  | 8                     | 55                                      | 1.3                               | 0.4               |
| 150.0                              | C         | T520C157M004A(1)E015 | 60                                  | 8                     | 15                                      | 2.7                               | 0.9               |
| 150.0                              | C         | T520C157M004A(1)E025 | 60                                  | 8                     | 25                                      | 2.1                               | 0.7               |
| 150.0                              | C         | T520C157M004A(1)E045 | 60                                  | 8                     | 45                                      | 1.6                               | 0.5               |
| 150.0                              | C         | T520C157M004A(1)E100 | 60                                  | 8                     | 100                                     | 1.0                               | 0.3               |
| 150.0                              | V         | T520V157M004A(1)E007 | 60                                  | 10                    | 7                                       | 4.2                               | 1.3               |
| 150.0                              | V         | T520V157M004A(1)E009 | 60                                  | 10                    | 9                                       | 3.7                               | 1.2               |
| 150.0                              | V         | T520V157M004A(1)E012 | 60                                  | 10                    | 12                                      | 3.2                               | 1.0               |
| 150.0                              | V         | T520V157M004A(1)E015 | 60                                  | 10                    | 15                                      | 2.9                               | 0.9               |
| 150.0                              | V         | T520V157M004A(1)E025 | 60                                  | 10                    | 25                                      | 2.2                               | 0.7               |
| 150.0                              | D         | T520D157M004A(1)E007 | 60                                  | 10                    | 7                                       | 4.6                               | 1.5               |
| 220.0                              | B         | T520B227M004A(1)E035 | 88                                  | 8                     | 35                                      | 1.6                               | 0.5               |
| 220.0                              | B         | T520B227M004A(1)E045 | 88                                  | 8                     | 45                                      | 1.4                               | 0.4               |
| 220.0                              | B         | T520B227M004A(1)E070 | 88                                  | 8                     | 70                                      | 1.1                               | 0.3               |
| 220.0                              | C         | T520C227M004A(1)E015 | 88                                  | 8                     | 15                                      | 2.7                               | 0.9               |
| 220.0                              | C         | T520C227M004A(1)E018 | 88                                  | 8                     | 18                                      | 2.5                               | 0.8               |
| 220.0                              | C         | T520C227M004A(1)E025 | 88                                  | 8                     | 25                                      | 2.1                               | 0.7               |
| 220.0                              | C         | T520C227M004A(1)E045 | 88                                  | 8                     | 45                                      | 1.6                               | 0.5               |
| 220.0                              | C         | T520C227M004A(1)E055 | 88                                  | 8                     | 55                                      | 1.4                               | 0.4               |
| 220.0                              | L         | T520L227M004A(1)E012 | 88                                  | 8                     | 12                                      | 2.9                               | 0.9               |
| 220.0                              | L         | T520L227M004A(1)E025 | 88                                  | 10                    | 25                                      | 2.0                               | 0.6               |
| 220.0                              | W         | T520W227M004A(1)E040 | 88                                  | 10                    | 40                                      | 1.7                               | 0.5               |
| 220.0                              | V         | T520V227M004A(1)E007 | 88                                  | 10                    | 7                                       | 4.2                               | 1.3               |
| 220.0                              | V         | T520V227M004A(1)E009 | 88                                  | 10                    | 9                                       | 3.7                               | 1.2               |
| 220.0                              | V         | T520V227M004A(1)E012 | 88                                  | 10                    | 12                                      | 3.2                               | 1.0               |
| 220.0                              | V         | T520V227M004A(1)E015 | 88                                  | 10                    | 15                                      | 2.9                               | 0.9               |
| 220.0                              | V         | T520V227M004A(1)E018 | 88                                  | 10                    | 18                                      | 2.6                               | 0.8               |
| 220.0                              | V         | T520V227M004A(1)E025 | 88                                  | 10                    | 25                                      | 2.2                               | 0.7               |
| 220.0                              | V         | T520V227M004A(1)E040 | 88                                  | 10                    | 40                                      | 1.6                               | 0.6               |
| 220.0                              | V         | T520V227M004A(1)E045 | 88                                  | 10                    | 45                                      | 1.7                               | 0.5               |
| 220.0                              | D         | T520D227M004A(1)E006 | 88                                  | 10                    | 6                                       | 5.0                               | 1.7               |
| 220.0                              | D         | T520D227M004A(1)E007 | 88                                  | 10                    | 7                                       | 4.6                               | 1.5               |
| 220.0                              | D         | T520D227M004A(1)E012 | 88                                  | 10                    | 12                                      | 3.5                               | 1.1               |
| 220.0                              | D         | T520D227M004A(1)E065 | 88                                  | 10                    | 65                                      | 1.5                               | 0.5               |
| 330.0                              | C         | T520C337M004A(1)E025 | 132                                 | 8                     | 25                                      | 2.0                               | 0.6               |
| 330.0                              | V         | T520V337M004A(1)E007 | 132                                 | 10                    | 7                                       | 4.2                               | 1.3               |
| 330.0                              | V         | T520V337M004A(1)E009 | 132                                 | 10                    | 9                                       | 3.7                               | 1.2               |
| 330.0                              | V         | T520V337M004A(1)E012 | 132                                 | 10                    | 12                                      | 3.2                               | 1.0               |
| 330.0                              | V         | T520V337M004A(1)E018 | 132                                 | 10                    | 18                                      | 2.6                               | 0.8               |
| 330.0                              | V         | T520V337M004A(1)E025 | 132                                 | 10                    | 25                                      | 2.2                               | 0.7               |
| 330.0                              | V         | T520V337M004A(1)E040 | 132                                 | 10                    | 40                                      | 1.8                               | 0.6               |
| 330.0                              | D         | T520D337M004A(1)E006 | 132                                 | 10                    | 6                                       | 5.0                               | 1.7               |
| 330.0                              | D         | T520D337M004A(1)E007 | 132                                 | 10                    | 7                                       | 4.6                               | 1.5               |
| 330.0                              | D         | T520D337M004A(1)E009 | 132                                 | 10                    | 9                                       | 4.1                               | 1.3               |
| 330.0                              | D         | T520D337M004A(1)E012 | 132                                 | 10                    | 12                                      | 3.5                               | 1.1               |
| 330.0                              | D         | T520D337M004A(1)E015 | 132                                 | 10                    | 15                                      | 3.2                               | 1.0               |
| 330.0                              | D         | T520D337M004A(1)E040 | 132                                 | 10                    | 40                                      | 1.9                               | 0.6               |
| 330.0                              | D         | T520D337M004A(1)E045 | 132                                 | 8                     | 45                                      | 1.5                               | 0.5               |
| 470.0                              | D         | T520D477M004A(1)E010 | 188                                 | 10                    | 10                                      | 3.9                               | 1.2               |
| 470.0                              | D         | T520D477M004A(1)E012 | 188                                 | 10                    | 12                                      | 3.5                               | 1.1               |
| 470.0                              | D         | T520D477M004A(1)E015 | 188                                 | 10                    | 15                                      | 3.2                               | 1.0               |
| 470.0                              | D         | T520D477M004A(1)E018 | 188                                 | 10                    | 18                                      | 2.9                               | 0.9               |
| 470.0                              | D         | T520D477M004A(1)E025 | 188                                 | 10                    | 25                                      | 2.4                               | 0.8               |
| 470.0                              | D         | T520D477M004A(1)E040 | 188                                 | 10                    | 40                                      | 1.9                               | 0.6               |
| 680.0                              | D         | T520D687M004A(1)E012 | 272                                 | 10                    | 12                                      | 3.5                               | 1.2               |
| 680.0                              | D         | T520D687M004A(1)E015 | 272                                 | 10                    | 15                                      | 3.2                               | 1.1               |
| 680.0                              | D         | T520D687M004A(1)E025 | 272                                 | 10                    | 25                                      | 2.4                               | 0.8               |
| 680.0                              | Y         | T520Y687M004A(1)E010 | 272                                 | 10                    | 10                                      | 4.0                               | 1.3               |
| 680.0                              | Y         | T520Y687M004A(1)E015 | 272                                 | 10                    | 15                                      | 3.3                               | 1.0               |
| 680.0                              | Y         | T520Y687M004A(1)E025 | 272                                 | 10                    | 25                                      | 2.5                               | 0.8               |
| 680.0                              | X         | T520X687M004A(1)E010 | 272                                 | 10                    | 10                                      | 4.1                               | 1.3               |
| 680.0                              | X         | T520X687M004A(1)E015 | 272                                 | 10                    | 15                                      | 3.3                               | 1.0               |
| 680.0                              | X         | T520X687M004A(1)E035 | 272                                 | 10                    | 35                                      | 2.2                               | 0.7               |
| <b>6.3 Volt Rating @ 105°C</b>     |           |                      |                                     |                       |   |                                   |                   |
| 15.0                               | T         | T520T156M006A(1)E100 | 9.5                                 | 8                     | 100                                     | 0.8                               | 0.3               |
| 22.0                               | A         | T520A226M006A(1)E090 | 14                                  | 8                     | 90                                      | 0.9                               | 0.3               |
| 22.0                               | A         | T520A226M006A(1)E100 | 14                                  | 8                     | 100                                     | 0.9                               | 0.3               |
| 33.0                               | A         | T520A336M006A(1)E070 | 21                                  | 8                     | 70                                      | 1.0                               | 0.3               |
| 33.0                               | A         | T520A336M006A(1)E080 | 21                                  | 8                     | 80                                      | 1.0                               | 0.3               |
| 33.0                               | T         | T520T336M006A(1)E070 | 21                                  | 8                     | 70                                      | 0.9                               | 0.4               |
| 33.0                               | B         | T520B336M006A(1)E025 | 21                                  | 8                     | 25                                      | 1.8                               | 0.6               |
| 33.0                               | B         | T520B336M006A(1)E035 | 21                                  | 8                     | 35                                      | 1.5                               | 0.5               |
| 33.0                               | B         | T520B336M006A(1)E040 | 21                                  | 8                     | 40                                      | 1.5                               | 0.5               |
| 33.0                               | B         | T520B336M006A(1)E070 | 21                                  | 8                     | 70                                      | 1.1                               | 0.3               |
| 47.0                               | T         | T520T476M006A(1)E040 | 30                                  | 8                     | 40                                      | 1.3                               | 0.4               |
| 47.0                               | T         | T520T476M006A(1)E070 | 30                                  | 8                     | 70                                      | 1.0                               | 0.3               |
| 47.0                               | B         | T520B476M006A(1)E025 | 30                                  | 8                     | 25                                      | 1.8                               | 0.6               |
| 47.0                               | B         | T520B476M006A(1)E035 | 30                                  | 8                     | 35                                      | 1.6                               | 0.5               |
| 47.0                               | B         | T520B476M006A(1)E040 | 30                                  | 8                     | 40                                      | 1.5                               | 0.5               |
| 47.0                               | B         | T520B476M006A(1)E070 | 30                                  | 8                     | 70                                      | 1.1                               | 0.3               |
| 68.0                               | B         | T520B686M006A(1)E025 | 43                                  | 8                     | 25                                      | 1.8                               | 0.6               |
| 68.0                               | B         | T520B686M006A(1)E035 | 43                                  | 8                     | 35                                      | 2.4                               | 0.5               |
| 68.0                               | B         | T520B686M006A(1)E040 | 43                                  | 8                     | 40                                      | 1.5                               | 0.5               |
| 68.0                               | B         | T520B686M006A(1)E070 | 43                                  | 8                     | 70                                      | 1.1                               | 0.3               |
| 68.0                               | U         | T520U686M006A(1)E055 | 43                                  | 8                     | 55                                      | 1.3                               | 0.4               |
| 100.0                              | B         | T520B107M006A(1)E040 | 63                                  | 8                     | 40                                      | 1.5                               | 0.5               |
| 100.0                              | B         | T520B107M006A(1)E045 | 63                                  | 8                     | 45                                      | 1.4                               | 0.4               |
| 100.0                              | B         | T520B107M006A(1)E070 | 63                                  | 8                     | 70                                      | 1.1                               | 0.3               |
| 100.0                              | U         | T520U107M006A(1)E055 | 63                                  | 8                     | 55                                      | 1.3                               | 0.4               |
| 100.0                              | W         | T520W107M006A(1)E040 | 63                                  | 10                    | 40                                      | 1.7                               | 0.5               |
| 100.0                              | V         | T520V107M006A(1)E007 | 63                                  | 10                    | 7                                       | 4.2                               | 1.3               |
| 100.0                              | V         | T520V107M006A(1)E009 | 63                                  | 10                    | 9                                       | 3.7                               | 1.2               |
| 100.0                              | V         | T520V107M006A(1)E012 | 63                                  | 10                    | 12                                      | 3.2                               | 1.0               |
| 100.0                              | V         | T520V107M006A(1)E015 | 63                                  | 10                    | 15                                      | 2.9                               | 0.9               |
| 100.0                              | V         | T520V107M006A(1)E045 | 63                                  | 10                    | 45                                      | 1.7                               | 0.5               |
| 100.0                              | C         | T520C107M006A(1)E025 | 63                                  | 8                     | 25                                      | 2.1                               | 0.7               |
| 100.0                              | C         | T520C107M006A(1)E045 | 63                                  | 8                     | 45                                      | 1.6                               | 0.5               |
| 100.0                              | D         | T520D107M006A(1)E007 | 63                                  | 10                    | 7                                       | 4.6                               | 1.5               |
| 120.0                              | B         | T520B127M006A(1)E035 | 76                                  | 8                     | 35                                      | 1.8                               | 0.6               |
| 150.0                              | B         | T520B157M006A(1)E035 | 95                                  | 8                     | 35                                      | 1.6                               | 0.5               |
| 150.0                              | B         | T520B157M006A(1)E045 | 95                                  | 8                     | 45                                      | 1.4                               | 0.4               |
| 150.0                              | B         | T520B157M006A(1)E070 | 95                                  | 8                     | 70                                      | 1.1                               | 0.3               |
| 150.0                              | M         | T520M157M006A(1)E150 | 95                                  | 10                    | 150                                     | 0.7                               | 0.2               |
| 150.0                              | M         | T520M157M006A(1)E200 | 95                                  | 8                     | 200                                     | 0.6                               | 0.2               |
| 150.0                              | C         | T520C157M006A(1)E025 | 95                                  | 8                     | 25                                      | 2.1                               | 0.7               |
| 150.0                              | C         | T520C157M006A(1)E045 | 95                                  | 8                     | 45                                      | 1.6                               | 0.5               |
| 150.0                              | L         | T520L157M006A(1)E012 | 95                                  | 8                     | 12                                      | 2.9                               | 0.9               |
| 150.0                              | L         | T520L157M006A(1)E025 | 95                                  | 10                    | 25                                      | 2.0                               | 0.6               |
| 150.0                              | W         | T520W157M006A(1)E040 | 95                                  | 10                    | 40                                      | 1.7                               | 0.5               |
| 150.0                              | V         | T520V157M006A(1)E007 | 95                                  | 10                    | 7                                       | 4.2                               | 1.3               |
| 150.0                              | V         | T520V157M006A(1)E009 | 95                                  | 10                    | 9                                       | 3.7                               | 1.2               |
| 150.0                              | V         | T520V157M006A(1)E012 | 95                                  | 10                    | 12                                      | 3.2                               | 1.0               |
| 150.0                              | V         | T520V157M006A(1)E015 | 95                                  | 10                    | 15                                      | 2.9                               | 0.9               |
| 150.0                              | V         | T520V157M006A(1)E025 | 95                                  | 10                    | 25                                      | 2.2                               | 0.7               |
| 150.0                              | V         | T520V157M006A(1)E040 | 95                                  | 10                    | 40                                      | 1.8                               | 0.6               |
| 150.0                              | V         | T520V157M006A(1)E045 | 95                                  | 10                    | 45                                      | 1.7                               | 0.5               |
| 150.0                              | D         | T520D157M006A(1)E006 | 95                                  | 10                    | 6                                       | 5.0                               | 1.7               |
| 150.0                              | D         | T520D157M006A(1)E007 | 95                                  | 10                    | 7                                       | 4.6                               | 1.5               |
| 150.0                              | D         | T520D157M006A(1)E015 | 95                                  | 10                    | 15                                      | 3.2                               | 1.0               |
| 150.0                              | D         | T520D157M006A(1)E025 | 95                                  | 10                    | 25                                      | 2.4                               | 0.8               |
| 150.0                              | D         | T520D157M006A(1)E065 | 95                                  | 10                    | 65                                      | 1.7                               | 0.5               |
| 220.0                              | C         | T520C227M006A(1)E015 | 139                                 | 8                     | 15                                      | 2.7                               | 0.9               |
| 220.0                              | C         | T520C227M006A(1)E018 | 139                                 | 8                     | 18                                      | 2.5                               | 0.8               |
| 220.0                              | C         | T520C227M006A(1)E025 | 139                                 | 8                     | 25                                      | 2.0                               | 0.6               |
| 220.0                              | C         | T520C227M006A(1)E045 | 139                                 | 8                     | 45                                      | 1.5                               | 0.5               |

(1) To complete KEMET part number, insert letter designation for lead material from page 50. Higher voltage ratings and tighter tolerance product may be substituted with the same size as KEMET's option. Voltage substitutions will be marked with the higher voltage rating.

# CONDUCTIVE POLYMER CHIP CAPACITORS

## T520 Series - KO Cap



### T520 RATINGS & PART NUMBER REFERENCE

| Capacitance $\mu$ F                  | Case Size | KEMET Part Number    | DC Leakage $\mu$ A @ 25°C Max | DF% @ 25°C 120 Hz Max | ESR m $\Omega$ @ 25°C 100 kHz Max | Ripple Current Arms @ 100 kHz Max |                  |
|--------------------------------------|-----------|----------------------|-------------------------------|-----------------------|-----------------------------------|-----------------------------------|------------------|
|                                      |           |                      |                               |                       |                                   | w/ΔT=20°C @ -55°C to 85°C         | w/ΔT=2°C @ 105°C |
| <b>6.3 Volt Rating @ 105°C cont.</b> |           |                      |                               |                       |                                   |                                   |                  |
| 220.0                                | V         | T520V227M006A(1)E007 | 139                           | 10                    | 7                                 | 4.2                               | 1.3              |
| 220.0                                | V         | T520V227M006A(1)E009 | 139                           | 10                    | 9                                 | 3.7                               | 1.2              |
| 220.0                                | V         | T520V227M006A(1)E012 | 139                           | 10                    | 12                                | 3.2                               | 1.0              |
| 220.0                                | V         | T520V227M006A(1)E015 | 139                           | 10                    | 15                                | 2.9                               | 0.9              |
| 220.0                                | V         | T520V227M006A(1)E025 | 139                           | 10                    | 25                                | 2.2                               | 0.7              |
| 220.0                                | V         | T520V227M006A(1)E040 | 139                           | 10                    | 40                                | 1.8                               | 0.6              |
| 220.0                                | D         | T520D227M006A(1)E006 | 139                           | 10                    | 6                                 | 5.0                               | 1.7              |
| 220.0                                | D         | T520D227M006A(1)E007 | 139                           | 10                    | 7                                 | 4.6                               | 1.5              |
| 220.0                                | D         | T520D227M006A(1)E009 | 139                           | 10                    | 9                                 | 4.1                               | 1.3              |
| 220.0                                | D         | T520D227M006A(1)E015 | 139                           | 10                    | 15                                | 3.2                               | 1.0              |
| 220.0                                | D         | T520D227M006A(1)E040 | 139                           | 10                    | 40                                | 1.9                               | 0.6              |
| 220.0                                | D         | T520D227M006A(1)E050 | 139                           | 10                    | 50                                | 1.7                               | 0.5              |
| <b>6.3 Volt Rating @ 105°C</b>       |           |                      |                               |                       |                                   |                                   |                  |
| 330.0                                | V         | T520V337M006A(1)E015 | 208                           | 10                    | 15                                | 2.8                               | 0.9              |
| 330.0                                | V         | T520V337M006A(1)E018 | 208                           | 10                    | 18                                | 2.6                               | 0.8              |
| 330.0                                | V         | T520V337M006A(1)E025 | 208                           | 10                    | 25                                | 2.2                               | 0.7              |
| 330.0                                | V         | T520V337M006A(1)E040 | 208                           | 10                    | 40                                | 1.8                               | 0.6              |
| 330.0                                | V         | T520V337M006A(1)E045 | 208                           | 10                    | 45                                | 1.7                               | 0.5              |
| 330.0                                | D         | T520D337M006A(1)E009 | 208                           | 10                    | 9                                 | 4.1                               | 1.4              |
| 330.0                                | D         | T520D337M006A(1)E010 | 208                           | 10                    | 10                                | 3.9                               | 1.2              |
| 330.0                                | D         | T520D337M006A(1)E015 | 208                           | 10                    | 15                                | 3.2                               | 1.1              |
| 330.0                                | D         | T520D337M006A(1)E018 | 208                           | 10                    | 18                                | 2.9                               | 0.9              |
| 330.0                                | D         | T520D337M006A(1)E025 | 208                           | 10                    | 25                                | 2.4                               | 0.8              |
| 330.0                                | D         | T520D337M006A(1)E040 | 208                           | 10                    | 40                                | 1.9                               | 0.6              |
| 330.0                                | D         | T520D337M006A(1)E045 | 208                           | 10                    | 45                                | 1.8                               | 0.6              |
| 330.0                                | Y         | T520Y337M006A(1)E015 | 208                           | 10                    | 15                                | 3.3                               | 1.0              |
| 330.0                                | Y         | T520Y337M006A(1)E025 | 208                           | 10                    | 25                                | 2.5                               | 0.8              |
| 330.0                                | Y         | T520Y337M006A(1)E040 | 208                           | 10                    | 40                                | 2.0                               | 0.6              |
| 470.0                                | Y         | T520Y477M006A(1)E010 | 296                           | 10                    | 10                                | 4.0                               | 1.3              |
| 470.0                                | Y         | T520Y477M006A(1)E015 | 296                           | 10                    | 15                                | 3.3                               | 1.0              |
| 470.0                                | Y         | T520Y477M006A(1)E018 | 296                           | 10                    | 18                                | 3.0                               | 1.0              |
| 470.0                                | Y         | T520Y477M006A(1)E025 | 296                           | 10                    | 25                                | 2.5                               | 0.8              |
| 470.0                                | Y         | T520Y477M006A(1)E035 | 296                           | 10                    | 35                                | 2.1                               | 0.7              |
| 470.0                                | D         | T520D477M006A(1)E025 | 296                           | 10                    | 25                                | 2.4                               | 0.8              |
| 470.0                                | D         | T520D477M006A(1)E030 | 296                           | 10                    | 30                                | 2.2                               | 0.7              |
| 470.0                                | X         | T520X477M006A(1)E010 | 296                           | 10                    | 10                                | 4.1                               | 1.3              |
| 470.0                                | X         | T520X477M006A(1)E018 | 296                           | 10                    | 18                                | 3.0                               | 1.0              |
| 470.0                                | X         | T520X477M006A(1)E035 | 296                           | 10                    | 35                                | 2.2                               | 0.7              |
| 470.0                                | X         | T520X477M006A(1)E040 | 296                           | 10                    | 40                                | 2.0                               | 0.6              |
| <b>8 Volt Rating @ 105°C</b>         |           |                      |                               |                       |                                   |                                   |                  |
| 33.0                                 | T         | T520T336M008A(1)E070 | 26                            | 8                     | 70                                | 1.0                               | 0.3              |
| 33.0                                 | T         | T520T336M008A(1)E080 | 26                            | 8                     | 80                                | 0.9                               | 0.3              |
| 33.0                                 | B         | T520B336M008A(1)E025 | 26                            | 8                     | 25                                | 1.8                               | 0.6              |
| 33.0                                 | B         | T520B336M008A(1)E035 | 26                            | 15                    | 35                                | 1.5                               | 0.5              |
| 33.0                                 | B         | T520B336M008A(1)E040 | 26                            | 8                     | 40                                | 1.5                               | 0.5              |
| 33.0                                 | B         | T520B336M008A(1)E070 | 26                            | 8                     | 70                                | 1.1                               | 0.3              |
| 33.0                                 | U         | T520U336M008A(1)E070 | 26                            | 8                     | 70                                | 1.1                               | 0.4              |
| 47.0                                 | B         | T520B476M008A(1)E035 | 38                            | 8                     | 35                                | 1.6                               | 0.5              |
| 47.0                                 | B         | T520B476M008A(1)E070 | 38                            | 8                     | 70                                | 1.1                               | 0.3              |
| 82.0                                 | C         | T520C826M008A(1)E025 | 82                            | 8                     | 66                                | 2.1                               | 0.6              |
| 82.0                                 | C         | T520C826M008A(1)E045 | 82                            | 8                     | 66                                | 1.5                               | 0.2              |
| 150.0                                | D         | T520D157M008A(1)E025 | 120                           | 10                    | 25                                | 2.4                               | 0.8              |
| 150.0                                | D         | T520D157M008A(1)E040 | 120                           | 10                    | 40                                | 1.9                               | 0.6              |
| 150.0                                | D         | T520D157M008A(1)E055 | 120                           | 10                    | 55                                | 1.7                               | 0.5              |
| 150.0                                | V         | T520V157M008A(1)E040 | 120                           | 10                    | 40                                | 3.1                               | 1.0              |
| <b>10 Volt Rating @ 105°C</b>        |           |                      |                               |                       |                                   |                                   |                  |
| 10.0                                 | A         | T520A106M010A(1)E080 | 10                            | 8                     | 80                                | 1.0                               | 0.3              |
| 15.0                                 | A         | T520A156M010A(1)E080 | 15                            | 8                     | 80                                | 1.0                               | 0.3              |
| 22.0                                 | A         | T520A226M010A(1)E080 | 22                            | 8                     | 80                                | 0.9                               | 0.3              |
| 33.0                                 | T         | T520T336M010A(1)E070 | 33                            | 8                     | 70                                | 1.0                               | 0.3              |
| 33.0                                 | T         | T520T336M010A(1)E080 | 33                            | 8                     | 80                                | 0.9                               | 0.3              |
| 33.0                                 | B         | T520B336M010A(1)E025 | 33                            | 10                    | 25                                | 1.8                               | 0.6              |
| 33.0                                 | B         | T520B336M010A(1)E040 | 33                            | 8                     | 35                                | 1.5                               | 0.5              |
| 33.0                                 | B         | T520B336M010A(1)E035 | 33                            | 8                     | 40                                | 1.5                               | 0.5              |
| 33.0                                 | B         | T520B336M010A(1)E070 | 33                            | 8                     | 70                                | 1.1                               | 0.3              |
| 33.0                                 | U         | T520U336M010A(1)E070 | 33                            | 8                     | 70                                | 1.1                               | 0.4              |
| 47.0                                 | B         | T520B476M010A(1)E035 | 47                            | 8                     | 35                                | 1.6                               | 0.5              |
| 47.0                                 | B         | T520B476M010A(1)E070 | 47                            | 8                     | 70                                | 1.1                               | 0.3              |
| 47.0                                 | U         | T520U476M010A(1)E055 | 47                            | 8                     | 55                                | 1.2                               | 0.4              |
| 68.0                                 | U         | T520U686M010A(1)E055 | 68                            | 8                     | 55                                | 1.3                               | 0.4              |
| 68.0                                 | W         | T520W686M010A(1)E025 | 68                            | 10                    | 25                                | 2.2                               | 0.7              |
| 68.0                                 | W         | T520W686M010A(1)E040 | 68                            | 10                    | 40                                | 1.7                               | 0.5              |
| 68.0                                 | C         | T520C686M010A(1)E045 | 68                            | 8                     | 45                                | 1.6                               | 0.5              |
| 68.0                                 | V         | T520V686M010A(1)E025 | 68                            | 10                    | 25                                | 2.2                               | 0.7              |
| 68.0                                 | V         | T520V686M010A(1)E040 | 68                            | 10                    | 40                                | 1.8                               | 0.6              |
| 68.0                                 | V         | T520V686M010A(1)E045 | 68                            | 10                    | 45                                | 1.7                               | 0.5              |
| 68.0                                 | V         | T520V686M010A(1)E060 | 68                            | 10                    | 60                                | 1.4                               | 0.5              |
| 68.0                                 | V         | T520V686M010A(1)E100 | 68                            | 10                    | 100                               | 1.1                               | 0.4              |
| 68.0                                 | D         | T520D686M010A(1)E100 | 68                            | 10                    | 100                               | 1.2                               | 0.4              |
| 100.0                                | C         | T520C107M010A(1)E025 | 100                           | 8                     | 25                                | 2.1                               | 0.4              |
| 100.0                                | C         | T520C107M010A(1)E045 | 100                           | 8                     | 45                                | 1.5                               | 0.5              |
| 100.0                                | L         | T520L107M010A(1)E025 | 100                           | 10                    | 25                                | 2.0                               | 0.6              |
| 100.0                                | W         | T520W107M010A(1)E040 | 100                           | 10                    | 40                                | 1.7                               | 0.5              |
| 100.0                                | V         | T520V107M010A(1)E018 | 100                           | 10                    | 18                                | 2.6                               | 0.8              |
| 100.0                                | V         | T520V107M010A(1)E025 | 100                           | 10                    | 25                                | 2.2                               | 0.7              |
| 100.0                                | V         | T520V107M010A(1)E045 | 100                           | 10                    | 45                                | 1.7                               | 0.5              |
| 100.0                                | V         | T520V107M010A(1)E050 | 100                           | 10                    | 50                                | 1.6                               | 0.5              |
| 100.0                                | D         | T520D107M010A(1)E018 | 100                           | 10                    | 18                                | 2.9                               | 0.9              |
| 100.0                                | D         | T520D107M010A(1)E055 | 100                           | 10                    | 55                                | 1.7                               | 0.5              |
| 100.0                                | D         | T520D107M010A(1)E080 | 100                           | 10                    | 80                                | 1.4                               | 0.4              |
| 150.0                                | D         | T520D157M010A(1)E025 | 150                           | 10                    | 25                                | 2.4                               | 0.8              |
| 150.0                                | D         | T520D157M010A(1)E040 | 150                           | 10                    | 40                                | 1.9                               | 0.6              |
| 150.0                                | D         | T520D157M010A(1)E055 | 150                           | 10                    | 55                                | 1.7                               | 0.5              |
| 220.0                                | Y         | T520Y227M010A(1)E040 | 220                           | 10                    | 40                                | 2.0                               | 0.6              |
| 220.0                                | D         | T520D227M010A(1)E018 | 220                           | 10                    | 18                                | 2.9                               | 0.9              |
| 220.0                                | D         | T520D227M010A(1)E025 | 220                           | 10                    | 25                                | 2.4                               | 0.8              |
| 220.0                                | D         | T520D227M010A(1)E040 | 220                           | 10                    | 40                                | 1.9                               | 0.6              |
| 330.0                                | Y         | T520Y337M010A(1)E015 | 330                           | 10                    | 15                                | 3.3                               | 1.0              |
| 330.0                                | Y         | T520Y337M010A(1)E035 | 330                           | 10                    | 35                                | 2.1                               | 0.4              |
| 330.0                                | X         | T520X337M010A(1)E010 | 330                           | 10                    | 10                                | 4.1                               | 1.3              |
| 330.0                                | X         | T520X337M010A(1)E025 | 330                           | 10                    | 25                                | 2.6                               | 0.8              |
| 330.0                                | X         | T520X337M010A(1)E040 | 330                           | 10                    | 40                                | 2.0                               | 0.6              |
| <b>16 Volt Rating @ 105°C</b>        |           |                      |                               |                       |                                   |                                   |                  |
| 22.0                                 | C         | T520C226M016A(1)E080 | 22                            | 8                     | 80                                | 1.2                               | 0.4              |
| 33.0                                 | W         | T520W336M016A(1)E045 | 53                            | 10                    | 60                                | 1.6                               | 0.5              |
| 33.0                                 | V         | T520V336M016A(1)E045 | 53                            | 10                    | 45                                | 1.7                               | 0.5              |
| 33.0                                 | V         | T520V336M016A(1)E060 | 53                            | 10                    | 60                                | 1.4                               | 0.5              |
| 33.0                                 | V         | T520V336M016A(1)E070 | 53                            | 10                    | 70                                | 1.0                               | 0.3              |
| 47.0                                 | W         | T520W476M016A(1)E045 | 75                            | 10                    | 45                                | 1.6                               | 0.5              |
| 47.0                                 | V         | T520V476M016A(1)E045 | 75                            | 10                    | 45                                | 1.7                               | 0.5              |
| 47.0                                 | V         | T520V476M016A(1)E070 | 75                            | 10                    | 70                                | 1.3                               | 0.4              |
| 47.0                                 | D         | T520D476M016A(1)E035 | 75                            | 10                    | 35                                | 2.1                               | 0.7              |
| 47.0                                 | D         | T520D476M016A(1)E070 | 75                            | 10                    | 70                                | 1.5                               | 0.5              |
| 68.0                                 | D         | T520D686M016A(1)E050 | 109                           | 10                    | 50                                | 1.7                               | 0.5              |
| 150.0                                | X         | T520X157M016A(1)E040 | 240                           | 10                    | 40                                | 2.6                               | 0.8              |
| <b>20 Volt Rating @ 105°C</b>        |           |                      |                               |                       |                                   |                                   |                  |
| 22.0                                 | V         | T520V226M020A(1)E040 | 44                            | 10                    | 40                                | 1.8                               | 0.6              |
| 22.0                                 | V         | T520V226M020A(1)E045 | 44                            | 10                    | 45                                | 1.6                               | 0.2              |
| 22.0                                 | V         | T520V226M020A(1)E090 | 44                            | 10                    | 90                                | 1.2                               | 0.4              |
| <b>25 Volt Rating @ 105°C</b>        |           |                      |                               |                       |                                   |                                   |                  |
| 15.0                                 | D         | T520D156M025A(1)E080 | 38                            | 10                    | 80                                | 1.6                               | 0.5              |
| 15.0                                 | D         | T520D156M025A(1)E080 | 38                            | 10                    | 80                                | 1.4                               | 0.4              |

(1) To complete KEMET part number, insert letter designation for lead material from page 50. Higher voltage ratings and tighter tolerance product may be substituted with the same size as KEMET's option. Voltage substitutions will be marked with the higher voltage rating.

# KEMET TANTALUM AND ALUMINUM CHIP CAPACITORS

CHARGED™

## Packaging Information

### Tape & Reel Packaging

KEMET's Molded Tantalum and Aluminum Chip Capacitor families are packaged in 8 mm and 12 mm plastic tape on 7" and 13" reels, in accordance with EIA Standard 481-1: Taping of Surface Mount Components for Automatic Handling. This packaging system is compatible with all tape fed automatic pick and place systems.

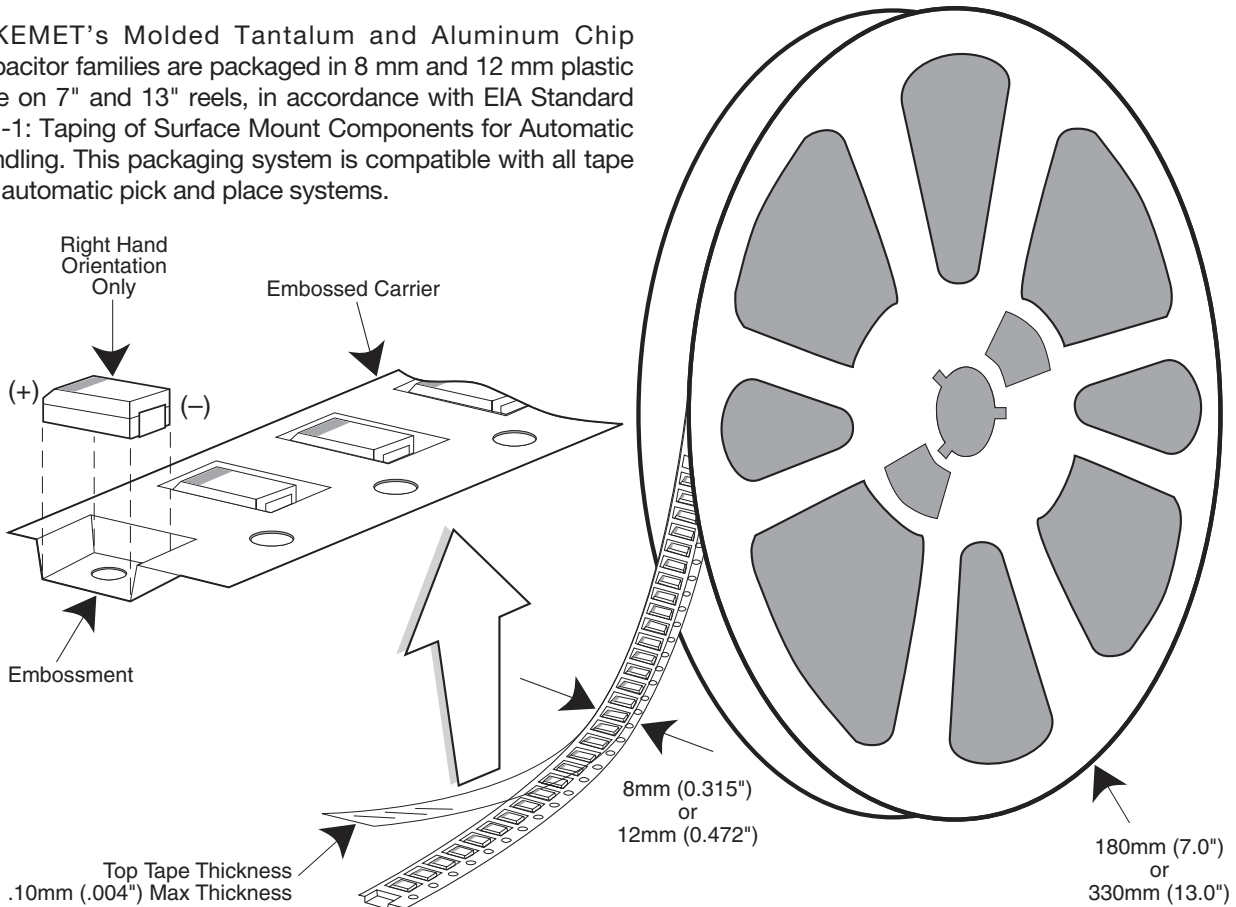

**Labeling:** Bar code labeling (standard or custom) shall be on the side of the reel opposite the sprocket holes. Refer to EIA-556.

### QUANTITIES PACKAGED PER REEL

| Case Code |         | Tape Width-mm | 7" Reel* | 13" Reel* |
|-----------|---------|---------------|----------|-----------|
| KEMET     | EIA     |               |          |           |
| R         | 2012-12 | 8             | 2,500    | 10,000    |
| S         | 3216-12 | 8             | 2,500    | 10,000    |
| T         | 3528-12 | 8             | 2,500    | 10,000    |
| U         | 6032-15 | 12            | 1,000    | 5,000     |
| W         | 7343-15 | 12            | 1,000    | 3,000     |
| V         | 7343-20 | 12            | 1,000    | 3,000     |
| A         | 3216-18 | 8             | 2,000    | 9,000     |
| B         | 3528-21 | 8             | 2,000    | 8,000     |
| C         | 6032-28 | 12            | 500      | 3,000     |
| D         | 7343-31 | 12            | 500      | 2,500     |
| Y         | 7343-40 | 12            | 500      | 2,000     |
| X         | 7343-43 | 12            | 500      | 2,000     |
| E         | 7260-38 | 12            | 500      | 2,000     |

\* No c-spec required for 7" reel packaging. C-7280 required for 13" reel packaging.

# TANTALUM, CERAMIC AND ALUMINUM CHIP CAPACITORS

## Packaging Information

### Performance Notes

- Cover Tape Break Force:** 1.0 Kg Minimum.
- Cover Tape Peel Strength:** The total peel strength of the cover tape from the carrier tape shall be:

| Tape Width | Peel Strength                          |
|------------|--|
| 8 mm       | 0.1 Newton to 1.0 Newton (10g to 100g) |
| 12 mm      | 0.1 Newton to 1.3 Newton (10g to 130g) |

The direction of the pull shall be opposite the direction of the carrier tape travel. The pull angle of the carrier tape shall be 165° to 180° from the plane of the carrier tape. During peeling, the carrier and/or cover tape shall be pulled at a velocity of 300 ±10 mm/minute.

- Reel Sizes:** Molded tantalum capacitors are available on either 180 mm (7") reels (standard) or 330 mm (13") reels (with C-7280). Note that 13" reels are preferred.
- Labeling:** Bar code labeling (standard or custom) shall be on the side of the reel opposite the sprocket holes. Refer to EIA-556.

### Embossed Carrier Tape Configuration: Figure 1

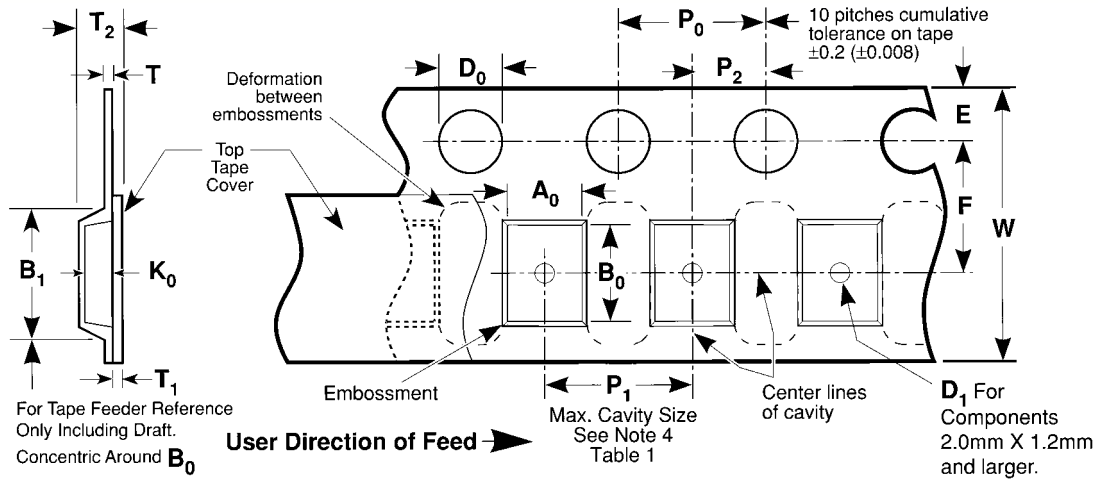

**Table 1 — EMBOSSED TAPE DIMENSIONS (Metric will govern)**

| Constant Dimensions — Millimeters (Inches) |  |                               |                               |                             |                             |                    |                    |                              |  |
|--|--|-------------------------------|-------------------------------|-----------------------------|-----------------------------|--------------------|--------------------|------------------------------|--|
| Tape Size                                  | D <sub>0</sub>                               | E                             | P <sub>0</sub>                | P <sub>2</sub>              | T Max                       | T <sub>1</sub> Max |                    |                              |  |
| 8 mm and 12 mm                             | 1.5<br>+0.10 -0.0<br>(0.059<br>+0.004, -0.0) | 1.75 ±0.10<br>(0.069 ±0.004)  | 4.0 ±0.10<br>(0.157 ±0.004)   | 2.0 ±0.05<br>(0.079 ±0.002) | 0.600<br>(0.024)            | 0.100<br>(0.004)   |                    |                              |  |
| Variable Dimensions — Millimeters (Inches) |  |                               |                               |                             |                             |                    |                    |                              |  |
| Tape Size                                  | Pitch  | B <sub>1</sub> Max.<br>Note 1 | D <sub>1</sub> Min.<br>Note 2 | F                           | P <sub>1</sub>              | R Min.<br>Note 3   | T <sub>2</sub> Max | W                            | A <sub>0</sub> B <sub>0</sub> K <sub>0</sub><br>Note 4 |
| 8 mm                                       | Single<br>(4 mm)                             | 4.4<br>(0.173)                | 1.0<br>(0.039)                | 3.5 ±0.05<br>(0.138 ±0.002) | 4.0 ±0.10<br>(0.157 ±0.004) | 25.0<br>(0.984)    | 2.5<br>(0.098)     | 8.0 ±0.30<br>(.315 ±0.012)   |  |
| 12 mm                                      | Double<br>(8 mm)                             | 8.2<br>(0.323)                | 1.5<br>(0.059)                | 5.5 ±0.05<br>(0.217 ±0.002) | 8.0 ±0.10<br>(0.315 ±0.004) | 30.0<br>(1.181)    | 4.6<br>(0.181)     | 12.0 ±0.30<br>(0.472 ±0.012) |  |

### NOTES

- B<sub>1</sub> dimension is a reference dimension for tape feeder clearance only.
- The embossment hole location shall be measured from the sprocket hole controlling the location of the embossment. Dimensions of embossment location and hole location shall be applied independent of each other.
- Tape with components shall pass around radius "R" without damage (see sketch A). The minimum trailer length (Fig. 2) may require additional length to provide R min. for 12 mm embossed tape for reels with hub diameters approaching N min. (Table 2)
- The cavity defined by A<sub>0</sub>, B<sub>0</sub>, and K<sub>0</sub> shall be configured to surround the part with sufficient clearance such that the chip does not protrude beyond the sealing plane of the cover tape, the chip can be removed from the cavity in a vertical direction without mechanical restriction, rotation of the chip is limited to 20 degrees maximum in all 3 planes, and lateral movement of the chip is restricted to 0.5 mm maximum in the pocket (not applicable to vertical clearance.)

# TANTALUM, CERAMIC AND ALUMINUM CHIP CAPACITORS



## Packaging Information

### Embossed Carrier Tape Configuration (cont.)

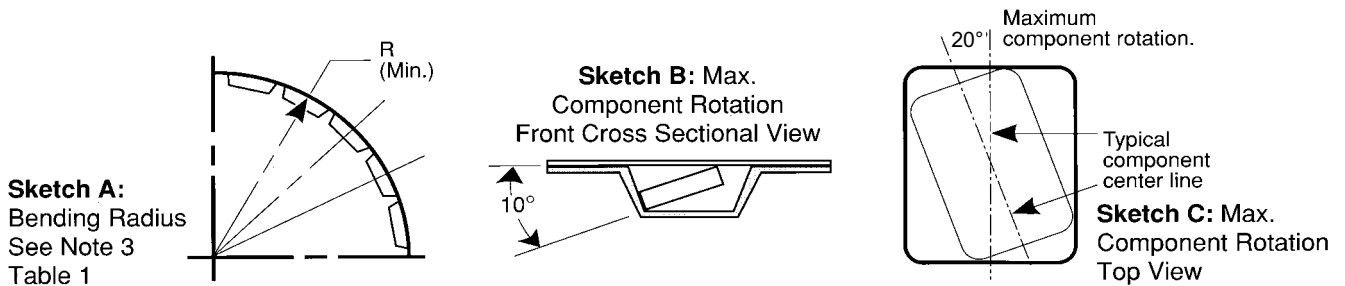

### Sketch D: Tape Camber (Top View)

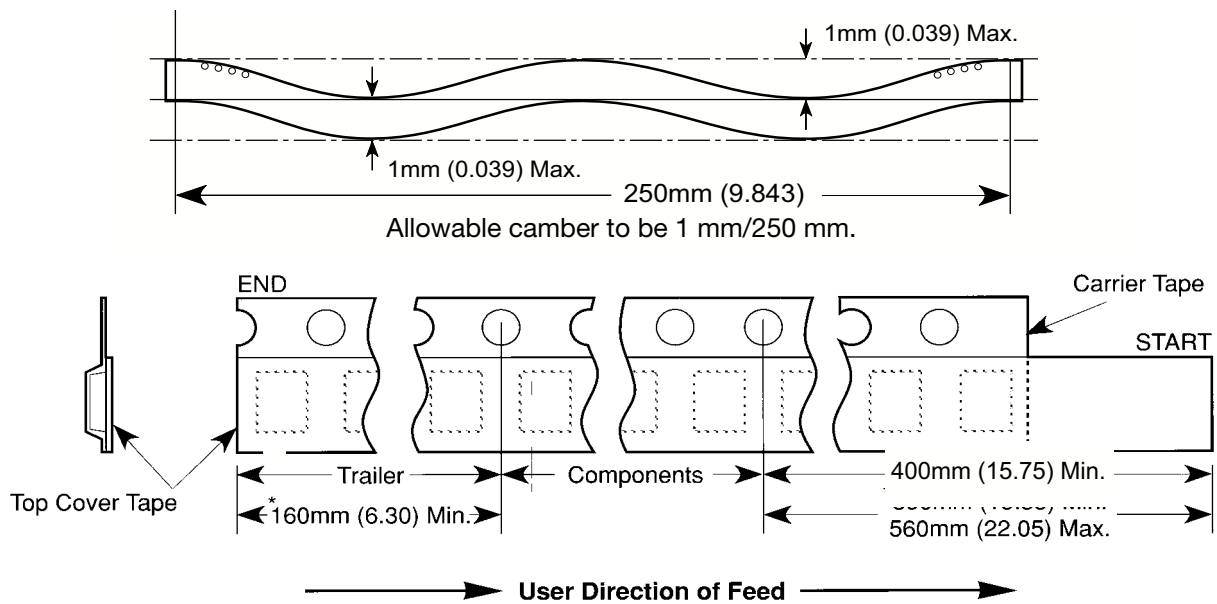

**Figure 2:** Tape Leader & Trailer Dimensions (Metric Dimensions Will Govern)

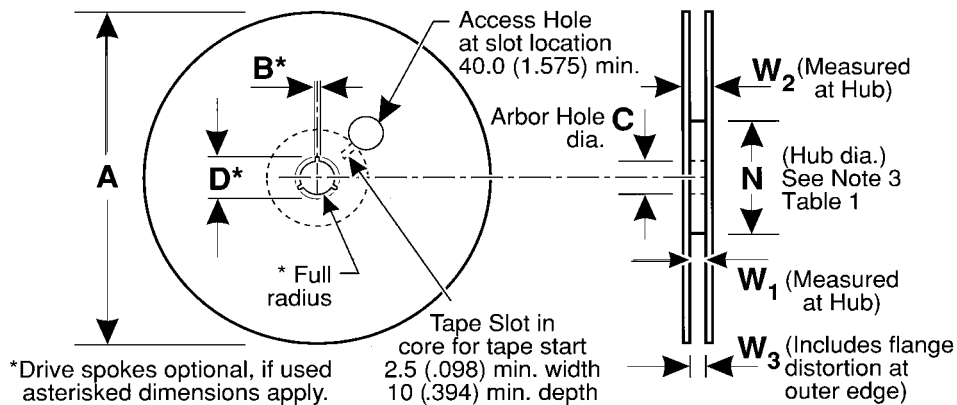

**Figure 3:** Reel Dimensions (Metric Dimensions will govern)

**Table 2 – REEL DIMENSIONS (Metric will govern)**

| Tape Size | A Max             | B* Min         | C                              | D* Min          | N Min                                    | W <sub>1</sub>                                | W <sub>2</sub> Max | W <sub>3</sub>                             |
|-----------|-------------------|----------------|--------------------------------|-----------------|--|---|--------------------|--|
| 8 mm      | 330.0<br>(12.992) | 1.5<br>(0.059) | 13.0 ± 0.20<br>(0.512 ± 0.008) | 20.2<br>(0.795) | 50.0<br>(1.969)<br>See Note 3<br>Table 1 | 8.4<br>+1.5, -0.0<br>(0.331<br>+0.059, -0.0)  | 14.4<br>(0.567)    | 7.9 Min<br>(0.311)<br>10.9 Max<br>(0.429)  |
| 12 mm     | 330.0<br>(12.992) | 1.5<br>(0.059) | 13.0 ± 0.20<br>(0.512 ± 0.008) | 20.2<br>(0.795) | 50.0<br>(1.969)<br>See Note 3<br>Table 1 | 12.4<br>+2.0, -0.0<br>(0.488<br>+0.078, -0.0) | 18.4<br>(0.724)    | 11.9 Min<br>(0.469)<br>15.4 Max<br>(0.606) |